

# UNIPRESS

## STF SEMI-AUTOMATIC PANTS TOP FINISHER



- *Automatic Steam and Air Cycles*
- *High Temperature Air For Fast Drying*
- *Handles Sizes 23-46*
- *Foot Controlled Waist Band Expander*
- *Adjustable Timers*
- *Easy Access For Maintenance*
- *Fly Clamp*
- *Designed And Manufactured in U.S.A.*

# STF TECHNICAL DATA

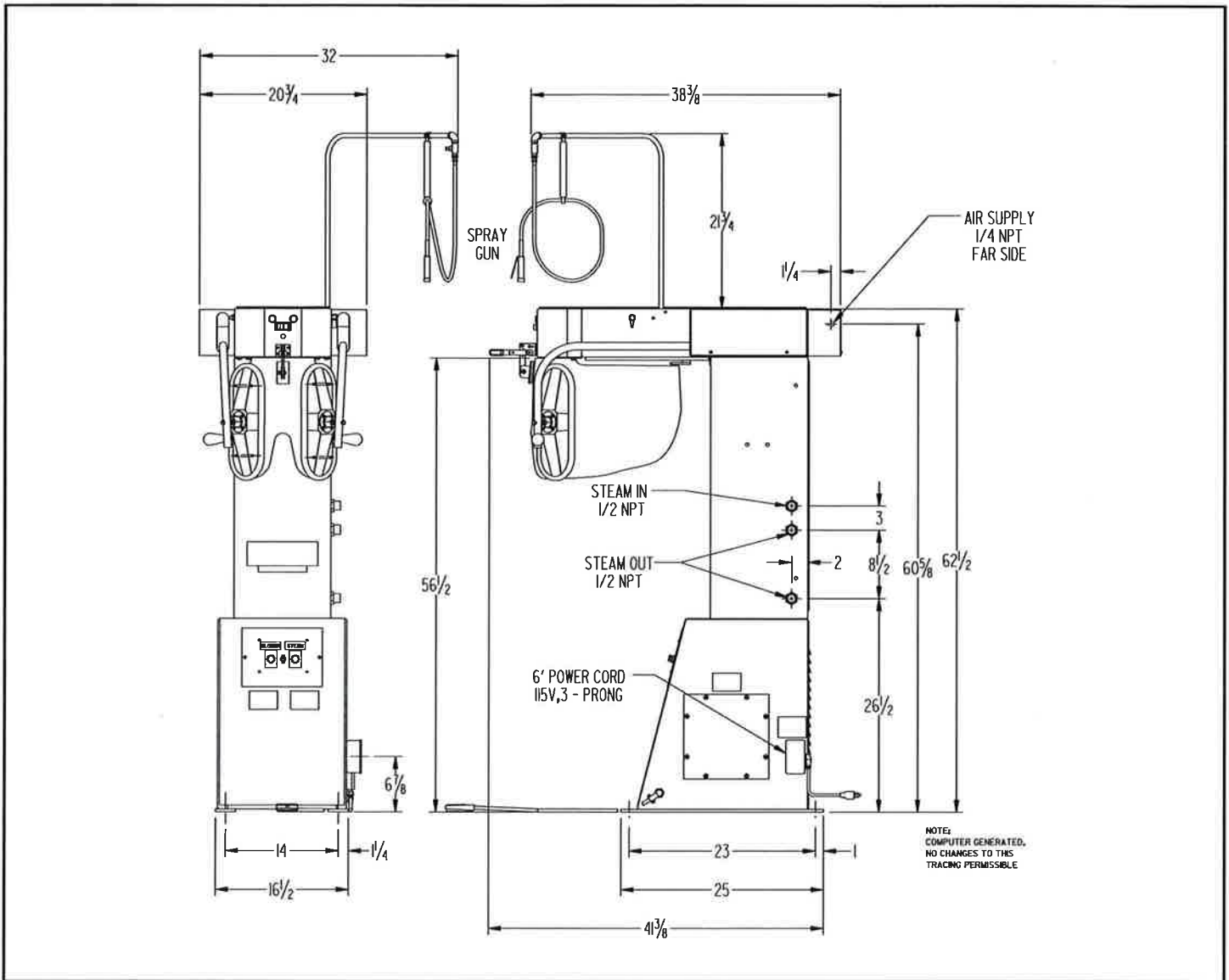

## SPECIFICATIONS

TYPE	STF
Overall Height	62 1/2"
Overall Length	41 3/8"
Overall Width	20 3/4"
Steam Inlet (1)	1/2" NPT
Steam Outlets (2)	1/2" NPT
Steam Supply	85 PSI
Boiler Horsepower	3/4 BHP
Electrical	115/1/60
Amperage	5 Amps
Net Weight	280 lbs.



Unipress reserves the right to alter or vary the specifications contained in this leaflet without notice. Drawings not to scale.

# UNIPRESS

3501 Queen Palm Drive Tampa, Florida 33619  
 Telephone (813) 623-3731 FAX (813) 626-2565  
[www.unipresscorp.com](http://www.unipresscorp.com)