

UNIPRESS

DC46 S Double Legger Press



The Unipress DC46 S is specifically designed to produce a top quality finish on all types of pants and fabrics. The unique design of the pressing head, buck and sandwich leaf eliminates side seam impressions and double creasing. The unit is fast and easy to operate, even trainees will quickly achieve high production and top quality.

- **Fast Smooth Operation**
- **Manual Sandwich Leaf**
- **Versatile** able to use as topper and utility press
- **Microprocessor Controls w/Self Diagnostics**

**Ultra High Production
and
Top Quality Finish**

DC46 S TECHNICAL DATA

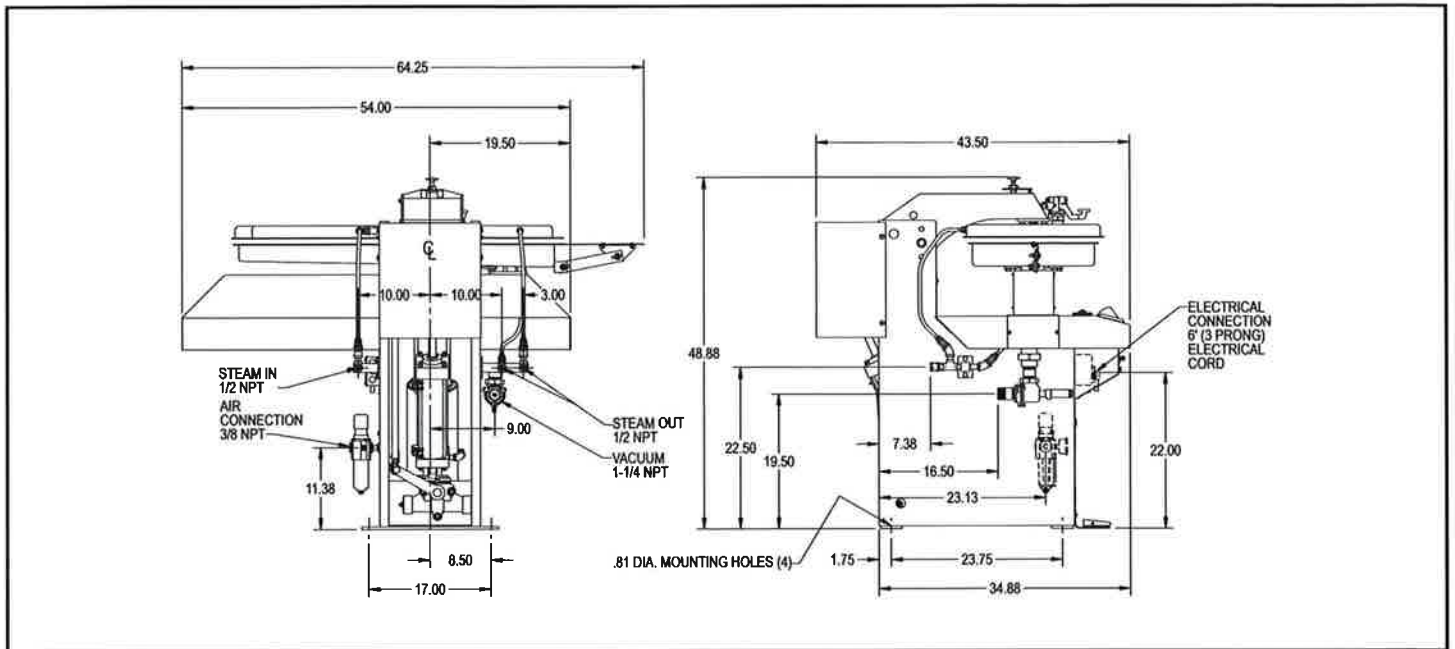

BUCK DIMENSIONS

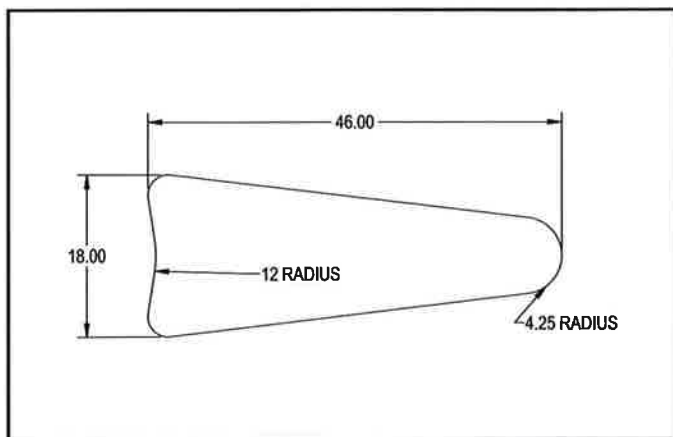

For maximum production and quality use model DC46 S with the following Unipress Toppers

ATT Tensioning Topper
TPF-PA Tensioning Topper



SPECIFICATIONS

	DC46 S
Height of buck - padded	40 1/2"
Length of buck - unpadded	46"
Width of buck - unpadded	18"
Width of machine	64 1/4"
Depth of machine	43 1/2"
Steam inlet (1)	1/2" NPT
Steam outlet (2)	1/2" NPT
Steam supply	85 PSI
Boiler horsepower	1
Vacuum outlet	1-1/4" NPT
Air inlet	3/8" NPT
Air consumption/cycle	1/2 Cu. Ft.
Air supply	85 PSI
Electrical	115/1/60
Amperage	1/2 AMP
Net weight	800 lbs

UNIPRESS

3501 Queen Palm Drive Tampa, Florida 33619
 Telephone (813) 626-3731 FAX (813) 626-2565

www.unipresscorp.com