

UNIPRESS

46X AUTOMATIC LEGGER-UTILITY DRY CLEANING PRESS



The Unipress Model 46X Automatic Legger-Utility Press is designed with the owner and operator in mind. Operators will love the fast smooth action as well as the extra wide head opening. Owners appreciate the low capital cost, reliability and minimal floor space. Combine these features with the following ones and you have a press that can't be beat.

- Automatic/Manual Operation
- Microprocessor Controls with Self Diagnostics
- Durable Construction
- Finger Tip Pressure
- Quiet Operation
- Adjustable Timers
- Designed and Manufactured in USA
- Single Action Cylinder

46X TECHNICAL DATA

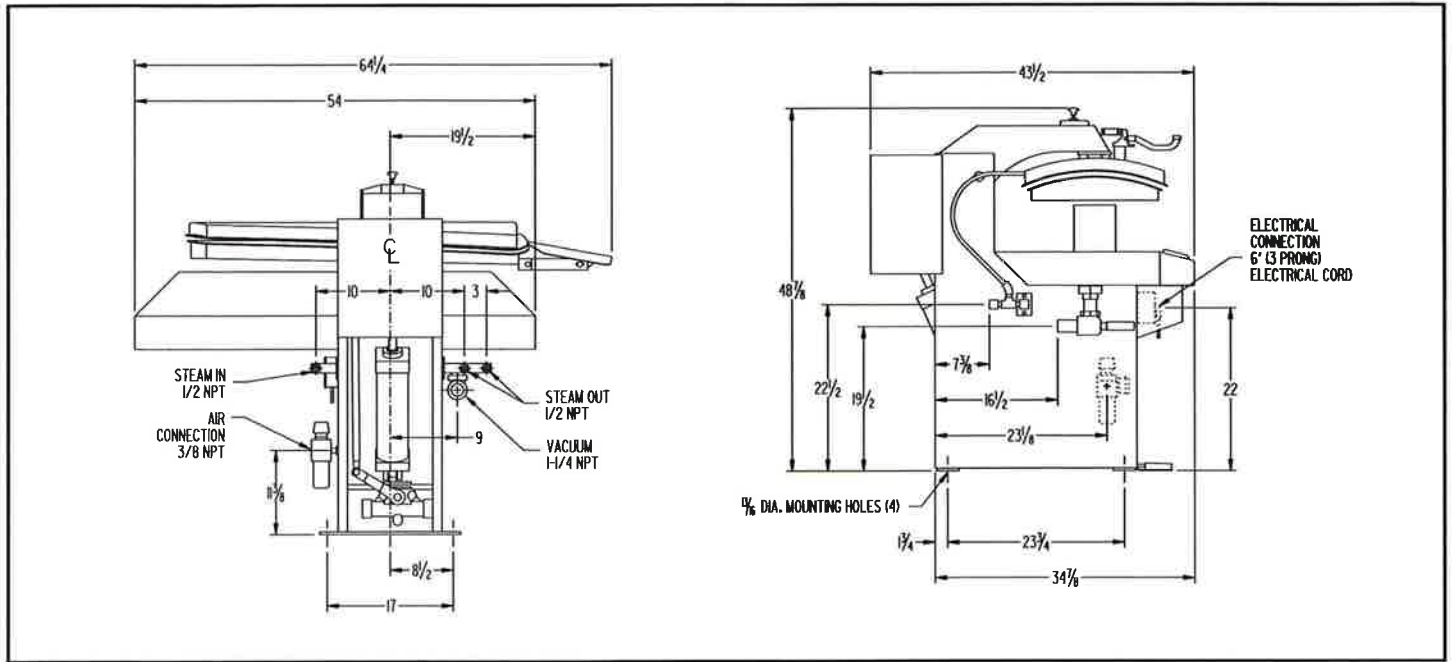

BUCK DIMENSIONS

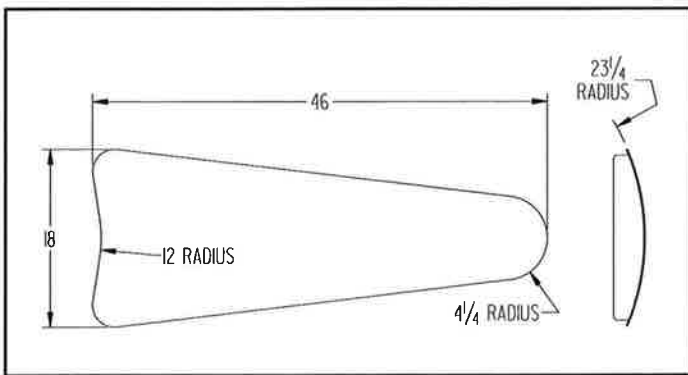

For maximum quality and production use model 46X with any of the following models:

- **TPFP Tension Topper**
- **STF Topper**
- **MTF Topper**
- **19MX Topper**
- **PI-1 Puff Iron**

SPECIFICATIONS

	46X
Height of buck - padded	40 1/2"
Length of buck - unpadded	46"
Width of buck - unpadded	18"
With of machine	64 1/4"
Depth of machine	43 1/2"
Steam inlet (1)	1/2" NPT
Steam outlet (2)	1/2" NPT
Vacuum outlet	1 1/4" NPT
Air inlet	3/8" NPT
Air supply	85 PSI
Air consumption/cycle	1 Cu. Ft.
Boiler horsepower rating	1 HP
Net Weight	825 Lbs.
Electrical	115/1/60
Amperage	1/2 Amp



UNIPRESS

3501 Queen Palm Drive Tampa, Florida 33619
Telephone (813) 623-3731 FAX (813) 626-2565

www.unipresscorp.com