

UNIPRESS

42XH HOT HEAD UTILITY DRY CLEANING PRESS



The Unipress model 42XH is excellent for handling tough garments such as silk, linen, cotton, and ramie. It makes it fast and easy to beautifully finish these types of garments. The steam chamber is designed to heat the head evenly to achieve the temperatures necessary to properly finish these garments.

The 42XH is truly a time saver plus it has many additional outstanding features:

- Wide Head Opening
- Fast Smooth Operation
- Finger Tip Pressure Regulator
- Single Cylinder Action
- Minimum of Floor Space
- Microprocessor Controls with Self Diagnostics
- Heavy Duty Steel Frame Construction

42XH TECHNICAL DATA

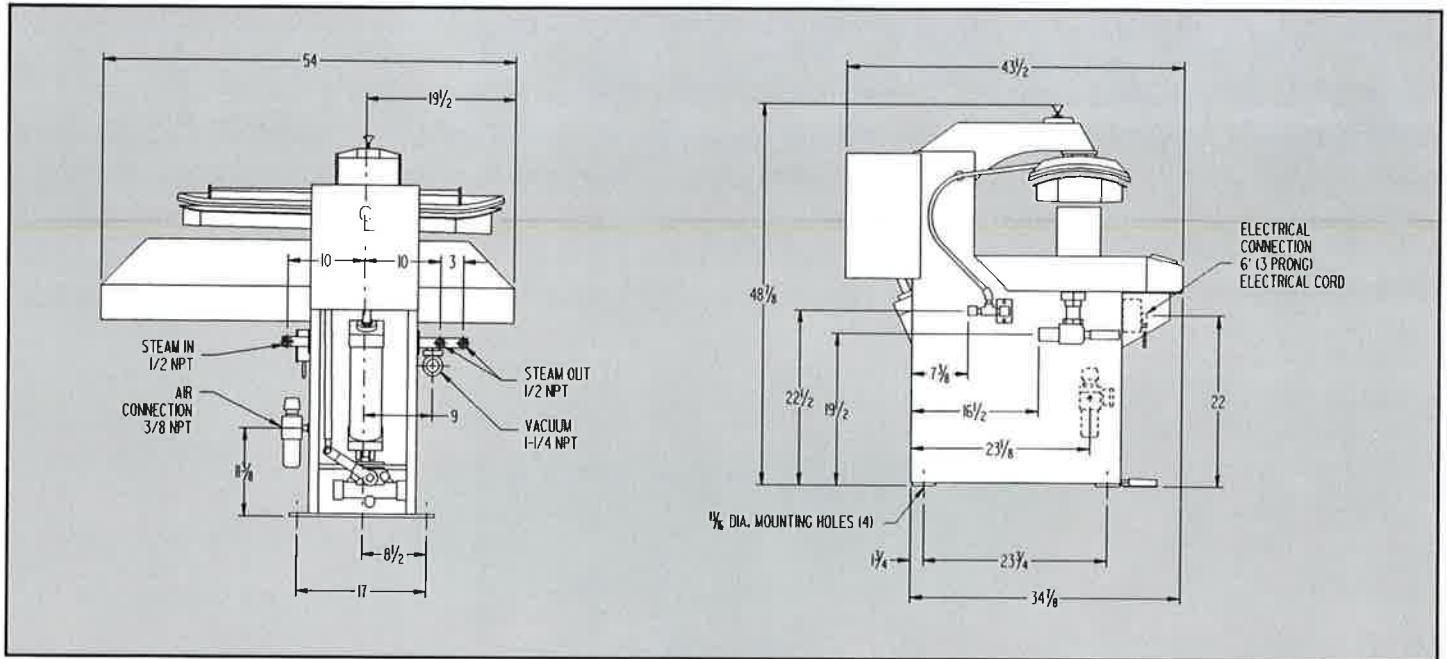

BUCK DIMENSIONS

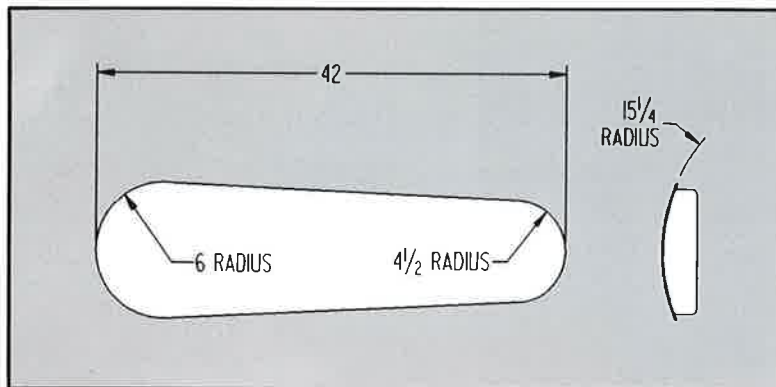

SPECIFICATIONS

| | 42XH |
|---------------------------|-------------|
| Height of buck - padded | 40 1/2" |
| Length of buck - unpadded | 42" |
| Width of buck - unpadded | 12" |
| Width of machine | 54" |
| Depth of machine | 43 1/2" |
| Steam inlet (1) | 1/2" NPT |
| Steam outlet (2) | 1/2" NPT |
| Vacuum outlet | 1 1/4" NPT |
| Air inlet | 3/8" NPT |
| Air supply | 85 PSI |
| Air consumption/cycle | 1/2 Cu. Ft. |
| Boiler horsepower rating | 1 HP |
| Net weight | 675 Lbs. |
| Electrical | 115/1/60 |
| Amperage | 1/2 Amp |



Available in right hand buck
(model 42 RXH) or
left hand buck (model 42 LXH)

UNIPRESS

3501 Queen Palm Drive Tampa, Florida 33619

Telephone (813) 623-3731 FAX (813) 626-2565

www.unipresscorp.com