



Published Manual Number/ECN: MATM2MICAE/9218BV

- Publishing System: TPAS
- Access date: 02/22/2000
- Document ECN's: Latest Available

Technical Reference—

Mark II Microprocessor Laundry Washer-Extractor Control

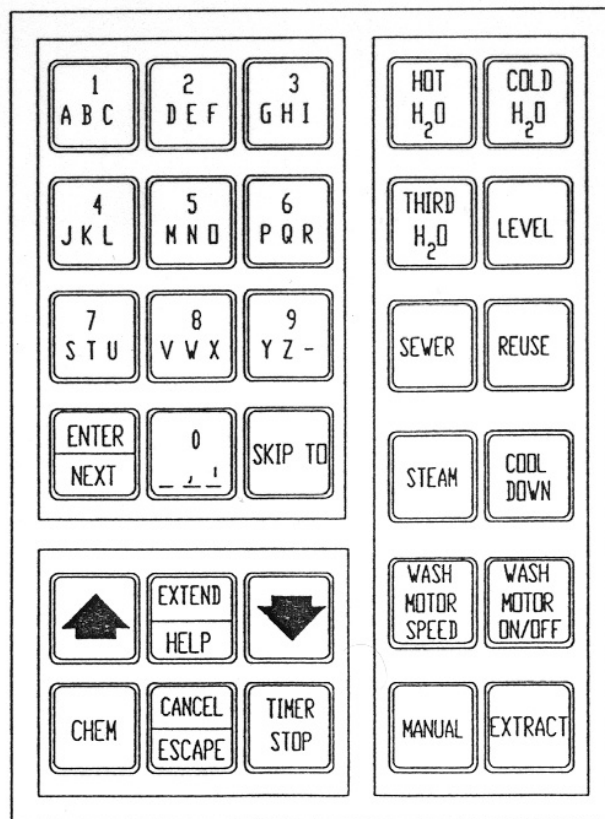

Please Read

About the Manual Identifying Information on the Cover

The front cover displays pertinent identifying information for this manual. Most important, are the published manual number (part number) /ECN (date code). Generally, when a replacement manual is furnished, it will have the same published manual number, but the latest available ECN. This provides the user with the latest information applicable to his machine. Similarly all documents comprising the manual will be the latest available as of the date the manual was printed, **even though older ECN dates for those documents may be listed in the table of contents.**

When communicating with the Milnor factory regarding this manual, please also provide the other identifying information shown on the cover, including the publishing system, access date, and whether the document ECN's are the latest available or exact.

References to Yellow Troubleshooting Pages

This manual may contain references to "yellow pages." Although the pages containing troubleshooting procedures are no longer printed on yellow paper, troubleshooting instructions, if any, will be contained in the easily located "Troubleshooting" chapter or section. See the table of contents.

Trademarks of Pellerin Milnor Corporation

The following, some of which may be used in this manual, are trademarks of Pellerin Milnor Corporation:

| | | | | |
|-------------------------|----------------------------|----------------------------|---------------------|--------------------------|
| Ampsaver [®] | CBW [®] | Gear Guardian [®] | Milnet [®] | Staph-Guard [®] |
| Autolint [®] | Dye-Extractor [®] | Hands-Off [®] | Milnor [®] | System 4 [®] |
| Auto-Purge [®] | Dyextractor [®] | Hydro-Cushion [®] | Miltrac | System 7 [®] |
| Autovac | E-P Plus [®] | Mildata [®] | Miltron | Totaltrol [®] |

Comments and Suggestions

Help us to improve this manual by sending your comments to:

Pellerin Milnor Corporation
Attn: Technical Publications
P. O. Box 400
Kenner, LA 70063-0400

Fax: (504) 469-1849

Table of Contents

for MATM2MICAE/9218BV

Mark II Microprocessor Laundry Washer-Extractor Control

| Page | Description | Document/ECN |
|-----------|---|-------------------|
| 1 | Scope Of This Manual | MHTM2MICAE/9020BV |
| 3 | Section 1: Warnings and Notices | |
| 4 | Safety Instructions for Washer-Extractor Operation | MSOP0205AE/9322CV |
| 9 | Section 2: What To Do First | |
| 10 | What To Do First | MSOP0237AE/9020BV |
| 11 | The Mark II Microprocessor Washer Extractor Control | MSOP0235AE/90201V |
| 15 | Section 3: Programming | |
| 16 | Programming the Mark II Microprocessor Washer-Extractor Control | MSOP0234AE/9106EV |
| 47 | Section 4: Operating | |
| 48 | Running a Formula in Automatic with the Mark II Microprocessor Control | MSOP0239AE/9020BV |
| 52 | Viewing, Printing, & Clearing Accumulated Formula Data (for machines with software version 8900b & later) | MSOP0254AE/91203V |
| 56 | Manual Formula Modifications with the Mark II Microprocessor Control | MSOP0236AE/9020CV |
| 61 | How to Set Water Levels in Washer Extractors with Mark II Microprocessor Controls | MSSM0238AE/9020DV |
| 65 | Section 5: Troubleshooting | |
| 66 | Viewing Inputs/Outputs & Actuating Outputs on the Mark II Microprocessor Control | MSOP0238AE/9106DV |
| 72 | Mark II Error Messages | MSTS0208AE/9020CV |
| 77 | Section 6: Supplemental Information | |
| 78 | The Hardware In Serial-Type Microprocessors | MSFDA401DE/9020JV |
| 83 | How to Change EPROMS in Microprocessors and Where to Check the DC Voltages | MSSM0217AE/9020IV |
| 88 | The External Serial Link Cables and How to Construct Them | MSSM0227AE/9525AV |
| 92 | Serial Printer Specifications for Epson LX810 Printer | MSSM0251AE/9264CV |
| 94 | How "Chemwait" Works in Milnor Mark I, II, III, IV and V Microprocessor Washer-Extractor Controllers | MSSM0248AE/9526BV |
| 95 | Formula Worksheet for Mark II Microprocessor Washer Extractor Control | B22FM90034/90363L |

SCOPE OF THIS MANUAL

This instruction manual is intended to provide commissioning, programming, operating and troubleshooting instructions for the MARK II microprocessor control for laundry washer extractors.

This manual is not intended to include specific operating instructions for any particular model. (For example, how to open the door or tilt the machine or add chemicals, etc.) Appropriate, model-specific instruction manuals are furnished with the machine.

The Normal Display Sequence At Each Power-up

COPYRIGHT PELLERIN
MILNOR 1989

Copyright Statement

ALL RIGHTS RESERVED
MARK-2 WE' 89002/S

Software date code/language version (Example: S=Spanish). Where technical documents apply only to certain software versions, the date codes for those versions are shown in the applicability statement. **NEVER DOWN LOAD DATA BETWEEN MACHINES WITH DIFFERENT SOFTWARE DATE CODES.**

FORMULA CHECK SUM
03E0

The check sum changes with any programming changes. Record the check sum after each programming session, to protect against unauthorized programming.

RUN FORMULA
0 OR OK POWER OFF

Normal Run Display. This display must appear before the machine can be run or programmed.

Section
Warnings and Notices

1

READ BEFORE USING MACHINE!

MSOP0205AE/9322CV (1 of 5)

SAFETY INSTRUCTIONS FOR WASHER-EXTRACTOR OPERATION

General Safety Requirements (specific warnings, next page and throughout manual)

Incorrect installation, neglected preventive maintenance, abuse, and/or improper repairs or changes to the machine can cause unsafe operation and personal injuries, such as *multiple fractures, amputations, or death*. The owner or his selected representative (*owner/user*) is responsible for understanding and ensuring the proper operation and maintenance of the machine. The *owner/user* must familiarize himself with the contents of all machine instruction manuals. The *owner/user* should direct any questions about these instructions to a Milnor[®] dealer or the Milnor[®] Service department.

Most regulatory authorities (including OSHA in the USA) hold the *owner/user* ultimately responsible for maintaining a safe working environment. Therefore, the *owner/user* must do the following:

- recognize all foreseeable safety hazards within his facility and take actions to protect his personnel, equipment, and facility
- require that personnel are familiar with all functional and safety aspects of the machine
- ensure safety devices installed on the machine are in place and properly maintained
- ensure all machine parts and assemblies are properly maintained.

Laundry Facility—Provide a supporting floor that is strong and rigid enough to support--*with a reasonable safety factor and without undue or objectionable deflection*--the weight of the fully loaded machine and the forces transmitted by it during operation. (For washer-extractors, see “ABOUT THE FORCES TRANSMITTED BY MILNOR[®] WASHER-EXTRACTORS.”) Provide sufficient clearance for machine movement. Provide any safety guards, fences, restraints, devices, and verbal and/or posted restrictions necessary to prevent personnel, machines, or other moving machinery from accessing the machine or its path. Provide adequate ventilation to carry away heat and vapors. Ensure service connections to installed machines meet local and national safety standards, especially regarding the electrical disconnect (see the National Electric Code). Prominently post safety information, including signs showing the source of electrical disconnect.

Personnel—Inform personnel about hazard avoidance and the importance of care and common sense. Provide personnel with the safety and operating instructions that apply to them. Verify that personnel use proper safety and operating procedures. Verify that that personnel understand and abide by point-of-hazard tags on the machine and procedure-specific precautions in the instruction manuals.

Safety Devices—Ensure that no one eliminates or disables any safety device on the machine or in the facility. Do not allow machine to be used with any missing guard or cover. Service any failing or malfunctioning device before operating the machine.

Maintenance—Ensure the machine is inspected and serviced in accordance with the norms of good practice and with the preventive maintenance schedule. Replace belts, pulleys, brake shoes/disks, clutch plates/tires, rollers, seals, alignment guides, etc. before they are severely worn. Immediately investigate any

The Danger From a Rotating Cylinder

A tremendous amount of potential energy is stored in the rotating cylinder of any washer-extractor (even at slow speed). Washer-extractors are equipped with a *door interlock* designed to prevent the door from being opened if the cylinder is turning and to prevent the machine from starting unless the door is closed and locked.

Some smaller machines permit the door to be opened only during the first few minutes of the formula and only while the machine is rotating in wash speed. If the door is opened, the drain valve opens immediately, the formula terminates, and (provided the machine still has electric power) on most, a brake is immediately applied.

All larger washer-extractors are equipped with a spring-applied, air-released brake which remains applied as long as the door is open and stops the cylinder whenever any of the following occurs: 1) the extract cycle ends, 2) the extract is manually terminated, or 3) the machine loses electric power.

Most machines permit the cylinder to be inched or jogged at slow speed, but only with two hands.

⚠ DANGER ⚠



ENTANGLE HAZARD—The linen inside or hanging partially outside the turning cylinder can suddenly wrap around your hand, arm, or body and twist off/sever it.

- ☞ DO NOT put any part of your body in the machine while it is moving.
- ☞ DO NOT operate the machine with the door open.
- ☞ DO NOT open the door while the cylinder is turning.
- ☞ DO NOT touch the linen or load/unload machine while the cylinder is turning.
- ☞ DO NOT open the door if there is water in the machine. You can be scalded by hot water.
- ☞ DO NOT tamper with or disable any safety device on the machine.
- ☞ DO NOT operate the machine with a malfunctioning door interlock mechanism.
- ☞ DO NOT operate the machine with malfunctioning two hand inching, if so equipped.

⚠ DANGER ⚠



EXPLOSION HAZARD—A damaged cylinder can rip apart during extract, throwing out metal fragments at high speed like an exploding grenade, killing/injuring personnel and damaging property.

- ☞ DO NOT operate machine with any evidence of cylinder damage.

The Danger From Processing With Flammable Materials

Washer-extractors are manufactured specifically for use with water, *not with any type solvent nor with any other material that might be flammable*. They are not suitable for any type of solvent cleaning process.

⚠ DANGER ⚠

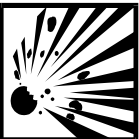

EXPLOSION AND FIRE HAZARDS—Goods containing flammable materials or fumes can explode or ignite spontaneously, killing/injuring personnel and damaging property.

- ☞ NEVER process goods containing any significant quantity of flammable chemical.

The Danger From Operating With Guards or Covers Removed

Like other types of industrial equipment, Milnor[®] washer-extractors utilize *high voltage electrical power* and, depending on model, pneumatic and hydraulic power to drive a wide variety of *moving parts*. Even with external power completely removed, the machine may contain energy such as tensioned springs, compressed air, and heavy parts that may fall if released. As previously stated, the washer cylinder acquires tremendous potential energy during extract, which must be absorbed by the brake or permitted sufficient time to dissipate. **Every guard, side panel, and door on the machine exists to isolate energized or moving parts from laundry personnel and must be securely in place for safe operation.**

⚠ DANGER ⚠



ELECTROCUTION HAZARD—Electric boxes and other electrical components contain high voltage that will kill or seriously injure you on contact. Power switch(es) on the machine disable only control circuit power, not three-phase power.

- ✎ **NEVER** operate the machine with electric box doors open or any electrical conductors exposed.
- ✎ **NEVER** attempt any electrical repair or troubleshooting unless you are a qualified electrician, authorized to work on the machine. Before proceeding, service personnel must consult all applicable safety and service information displayed on the machine and provided in the manuals.

⚠ DANGER ⚠



CRUSH AND ENTANGLE HAZARDS—Moving components such as belts, hydraulics, tilting machine housings, etc., can entangle, crush and/or sever parts of your body, killing or severely injuring you.

- ✎ **NEVER** operate machine with any guards, covers, or side panels removed.
- ✎ **NEVER** permit anyone to place any part of his body inside any part of the machine housing when the machine is operational.
- ✎ **NEVER** attempt any mechanical repair or troubleshooting unless you are a qualified mechanic, authorized to work on the machine. Before proceeding, service personnel must consult all applicable safety and service information displayed on the machine and provided in the manuals.
- ✎ **ALWAYS** make sure personnel are clear of machine before starting it.

The Danger From a Malfunctioning Clutch System

The low speed (wash speed) drive train *on machines with multiple motor drives* is disengaged during extract. At the end of extract, the cylinder will slow down before the low speed drive train is permitted to re-engage. **Although extremely unlikely in a properly maintained machine, a malfunction could cause the low speed drive to engage prematurely** (a possibility in all types of industrial machines that utilize clutches to switch between high speed and low speed operating cycles).

⚠ DANGER ⚠



EXPLOSION HAZARD *for machines with multiple motor drives*—Pulleys can be spun fast enough to explode into shrapnel-like fragments, injuring personnel and/or damaging property, if the low speed drive engages during or at the end of extract.

- ☞ **IMMEDIATELY** shut down the machine if any of these conditions occur:
 - The machine makes a sound like skidding automobile tires as it comes out of extract,
 - The wash or drain clutch does not disengage or it reengages during extract,
 - V-belts jump off at the start of, during, or at the end of extract,
 - A strange whining sound occurs at any time during extract.
- ☞ **DO NOT** permit the machine to operate until the cause of the offending condition is found and remedied.

Special Safety Considerations for Tilting Machines

Restricted areas must be established and maintained around tilting machines to protect laundry personnel from being struck or crushed when the machine tilts.

Tilt washer-extractors that pivot at *both the front and rear* of the machine have redundant *safety limit switches* and *electrical interlocks* designed to prevent the machine from 1) tilting forward (rear up) unless *both* front-down limit switches are depressed, and 2) tilting rearward (front up) unless *both* rear-down limit switches are depressed. Because the safety limit switches and electrical interlocks cannot be bypassed at the operator control panel, these ensure safe tilting during normal operation *if* the safety limit switches and all related components and circuitry are in proper working order. **Electrical interlocks and safety limit switches are ignored when the machine is tilted manually with the hydraulic tilting valves. This procedure must be restricted to competent, knowledgeable, authorized service personnel.**

⚠ DANGER ⚠



CRUSH HAZARD—Machine will crush body parts caught in mechanisms during tilting. Personnel behind, above, or in front of machine may be crushed if caught between machine and a nearby object during tilting.

- ☞ NEVER tilt machine with any guards, covers, or side panels removed.
- ☞ NEVER permit anyone to place any part of his body inside or under machine when the machine is operational.
- ☞ NEVER permit anyone on top of the machine or within restricted areas around the machine when the machine is operational. Laundry must restrict access to dangerous areas.
- ☞ ALWAYS ensure personnel are clear of machine before tilting.
- ☞ NEVER operate a tilting machine unless all tilting components, including but not limited to safety limit switches, electrical interlocks, and operator controls, are functioning properly.
- ☞ NEVER attempt to test or perform maintenance on any portion of the tilting mechanisms unless you are a qualified mechanic authorized to work on the machine. Before proceeding, service personnel must consult all applicable safety and service information displayed on the machine and provided in the manuals.
- ☞ NEVER attempt to tilt the machine using the hydraulic tilting valves unless you are a qualified mechanic authorized to work on the machine. Before using manual hydraulic controls, service personnel must thoroughly understand the system and all consequences of manual operation.

⚠ DANGER ⚠



CRUSH HAZARD for machines with both front and rear pivots—A tilted machine may lunge forward or rearward and even fall over, crushing personnel, if the tilt wheels at the non-tilted end are raised out of their cradles.

- ☞ NEVER tilt machine using the hydraulic tilting valves unless you are a qualified mechanic authorized to work on the machine. These valves bypass all safeties.



2

Section

What To Do First

WHAT TO DO FIRST

| | | |
|-------------|--|---|
| Situation A | | •Before commissioning a new machine |
| | | •When recommissioning a machine after a protracted shutdown |
| | | •After replacing the CPU |
| | | •After adding options |
| Situation B | | •If the display says “CLEAR MEMORY NOW” |
| | | •If the display says “CONFIG ERROR” (see below) |

The Mark II microprocessor washer-extractor control has a battery to protect its memory. A microprocessor with a new and fully charged battery should retain user-programmed memory for up to 3 months under ideal conditions. **The battery is trickle-charged whenever the machine is connected to power and the machine’s Master Switch is ON. To assure a fully charged battery, keep the machine connected to power and the Master Switch ON for at least 48 hours.**

The battery may not have been fully charged when the machine (or replacement board) was shipped, and one can never be certain how long a machine has been in transit or storage, or whether the machine was subjected to electromagnetic radiations during transit or storage. Therefore, **the following procedures, in the order shown, are mandatory in the following situations.**

FOR SITUATION A: (SEE ABOVE) WHEN DISPLAY DOES NOT SAY “CONFIG ERROR:”

1. **CLEAR ALL MEMORY** (See Program Menu, Mode 7)
2. **RECONFIGURE** (See Program Menu, Mode 5)
3. **RENAME STEP AND/OR CHEMICAL NAMES** if desired. (See Program Menu, Modes 3 & 4)
4. **PROGRAM THE WASH FORMULAS** (See Program Menu, Modes 1 & 6). Downloading (Program Menu, Mode 6) can be extremely helpful when programming wash formulas. However, downloading between different model controls, or different model machines, or machines with different options is subject to certain restrictions explained in Program Menu, Mode 6.

FOR SITUATION B: (SEE ABOVE) WHEN DISPLAY DOES SAY “CONFIG ERROR”:

1. **RECONFIGURE** (See Program Menu, Mode 5 and also “CONFIG ERROR” under “TROUBLESHOOTING ERROR MESSAGES” elsewhere in this manual.)
2. **CLEAR ALL MEMORY** (See Program Menu, Mode 7)
3. **RENAME STEP AND/OR CHEMICAL NAMES** if desired. (See Program Menu, Modes 3 & 4)
4. **PROGRAM THE WASH FORMULAS** (See further explanation above)

THE MARK II MICROPROCESSOR WASHER EXTRACTOR CONTROL

Three components of the Mark II control used to program and operate the microprocessor are:

- RUN/PROGRAM Keyswitch
- Display
- Keypad

The various components are more thoroughly described in the section entitled “THE HARDWARE IN MILNOR SERIAL TYPE MICROPROCESSORS” elsewhere in this manual.

Run/Program Keyswitch

The two position RUN/PROGRAM keyswitch provides security for all field-programmable data in memory. With the keyswitch set to RUN, this data cannot be changed. The key cannot be removed in the PROGRAM position.

AVOID DATA LOSS

1. Remove key except when actually programming. Never leave the key accessible to unauthorized personnel.
2. Never turn the key from PROGRAM to RUN unless the display says “PROGRAM 0 MENU” / “OK TURN KEY TO RUN” . Carefully review “HOW TO AVOID DATA LOSS!” in PROGRAMMING THE MARK II MICRO-PROCESSOR WASHER EXTRACTOR CONTROL in this manual before proceeding.

Display

The display contains two lines of data. The displayed information depends on what is happening at the time. Figure 1 shows what is displayed once “CHANGE CHEM NAMES” (Program Menu, Mode 4) has been accessed.

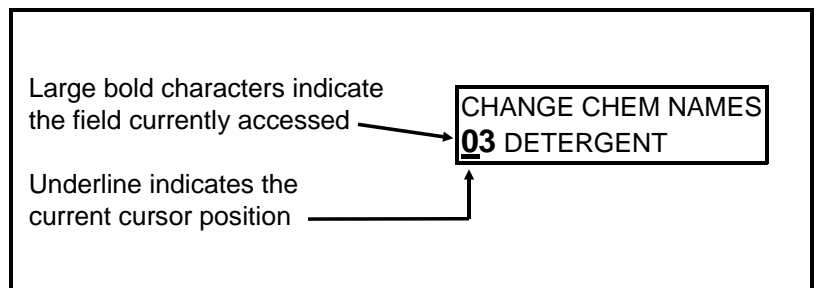

FIGURE 1 (MSOP0235AE)
Typical MARK II Display During Programming

**THE MARK II MICROPROCESSOR
WASHER EXTRACTOR CONTROL**

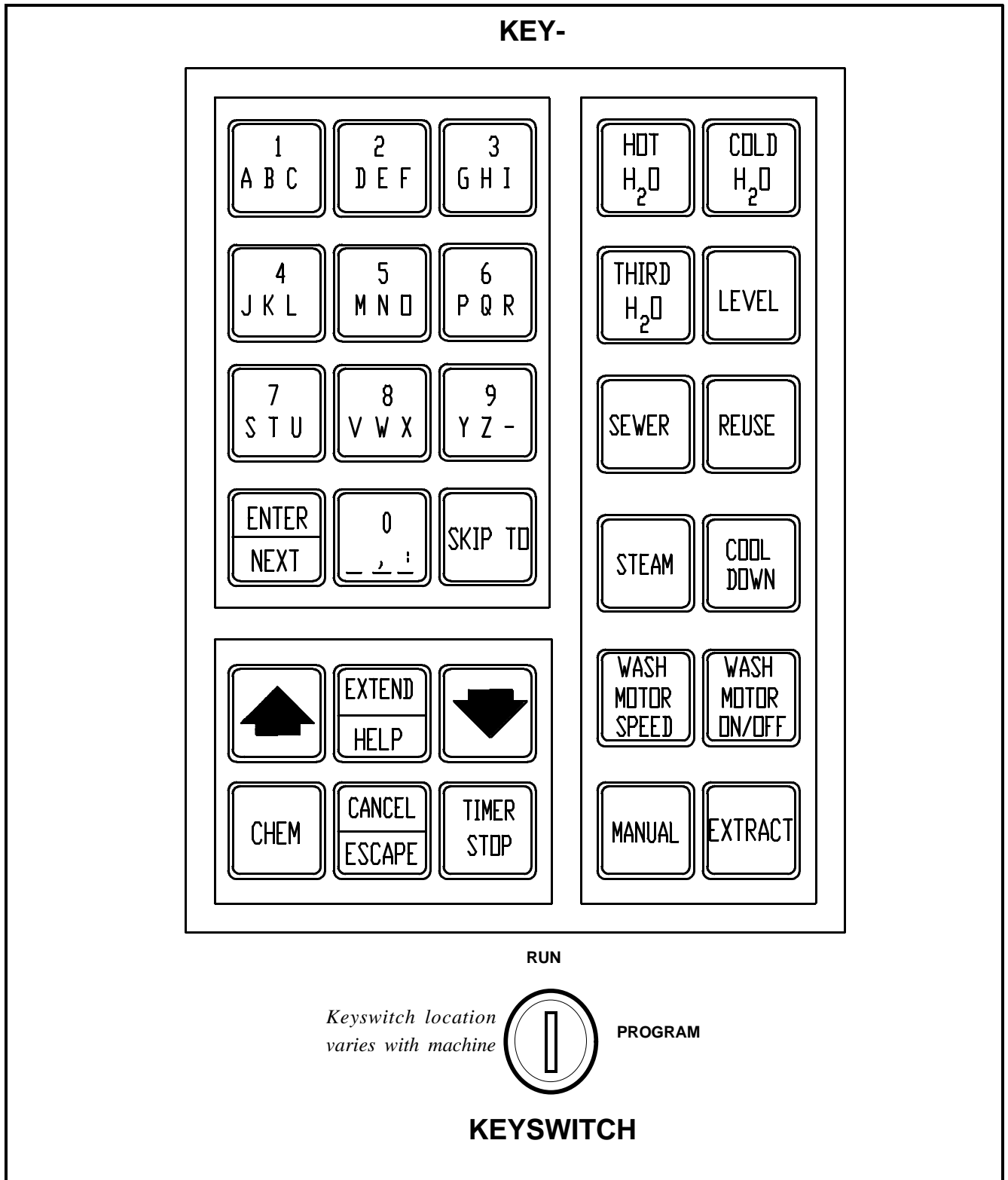





















FIGURE 2 (MSOP0235AE)
MARK II WASHER EXTRACTOR MICROPROCESSOR KEYPAD AND KEYSWITCH

Keypad And Symbology

The symbol used to show an individual key stroke is a box with the key function shown inside (i.e. ,). The key symbol may depict only the one word or character appropriate to the desired function even though several words or characters actually appear on the key.

| Symbology | What it means |
|--|--|
|  ,  | Turn keyswitch clockwise to PROGRAM, then press and release the ENTER/NEXT key. |
|  ,  | Turn the keyswitch counterclockwise to RUN, then press and release the ENTER/NEXT key. |
|  | Press and release the up arrow key. |
|  or  | Indicates that choices scroll up or down while the key is held depressed. |
|  ,  ,  ,  ,  ,  ,  | A “,” between symbols means to press and release each key in the order shown. In programming step names, the key strokes shown would spell out the name “SUDS”. Press and release the key one or more times (or hold it in) until the desired character appears. |
|  +  +  | A “+” between symbols means to press and hold each key in the order shown until all keys are held depressed at the same time, then release all keys. |
|  | Press and release the STOP button.(Not shown in accompanying drawing) |
|  | Press and release the START button.(Not shown in accompanying drawing) |

Section
Programming

3

PROGRAMMING THE MARK II MICROPROCESSOR WASHER-EXTRACTOR CONTROL

The Program Menu and How To Access It

The Available Modes In the Program Menu

- 0 = OK TURN KEY TO RUN (permits safe return to Run menu)
- 1 = ADD/CHANGE FORMULA (also add/delete steps or delete formula)
- 2 = COPY OLD TO NEW (copy existing formula to unused formula number)
- 3 = CHANGE STEP NAMES
- 4 = CHANGE CHEM NAMES
- 5 = CONFIGURE (tell computer which model and options it is controlling)
- 6 = DOWN LOAD (from machine to machine or machine to tape)
- 7 = CLEAR ALL MEMORY (VOLUNTARILY)
- 8 = PRINT DATA

To Access the Program Menu

When the display =

RUN FORMULA
00 OR OK TO POWER OFF

This is the Run Mode, explained in OPERATION. See table of contents.



(Turn keyswitch to "PROGRAM" then press "NEXT" key.)

PROGRAM 0 MENU
OK TURN KEY TO RUN

Program menu. Underline indicates cursor position. Select 1 of 8 program modes by number or with or or select before returning to Run Mode.



(Turn keyswitch to "RUN" then press the "NEXT" key)

Returns to Run display. Use only when 2nd line says "OK TURN KEY TO RUN".



Scrolls the available program modes.

example:

PROGRAM 1 MENU
ADD/CHANGE FORMULA

Program Menu, Mode 1 selected



Accesses the selected program mode.

example:

ADD/CHANGE FORMULA
00

Program Menu, Mode 1 accessed

See "HOW TO AVOID DATA LOSS", next page

How To Avoid Data Loss!

For Mark II Microprocessor Washer Extractor Control

 Returns to the Program Menu from any program mode (or displays instructions on how to escape).

Never   **unless the display says** 

Otherwise, the control will require either deleting a specific formula or clearing the entire memory.

If the control requires deleting the specific formula, it displays  (example)

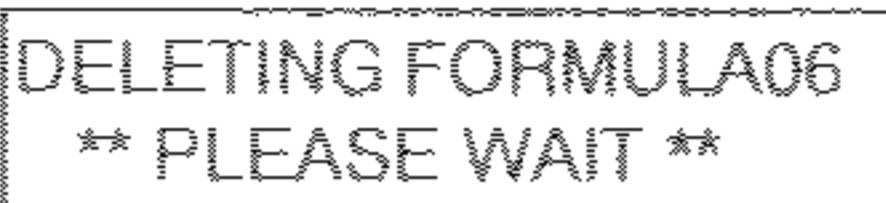
then  =  (example)





Display returns to 

Don't use the above procedure to voluntarily delete a specific formula. See Mode 1, ADD/CHANGE FORMULA for proper procedure.

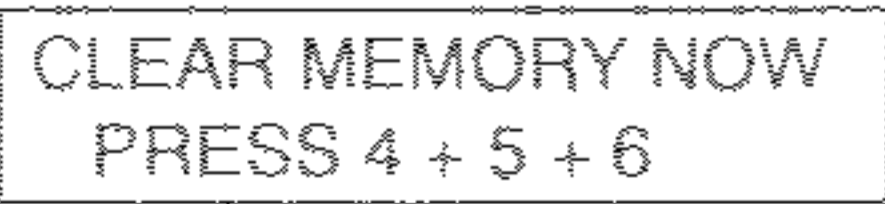
Never power OFF while in Program Mode.

Otherwise, the control will require deleting the entire memory.

If the control requires deleting the entire memory, it displays 

then  +  +  = 

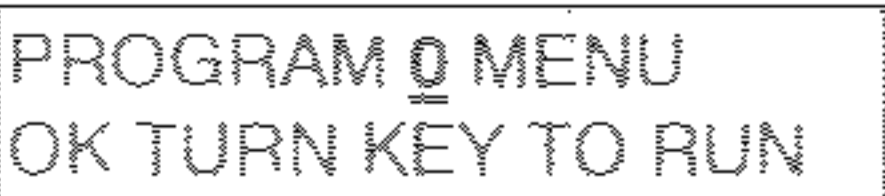
Display returns to 

Reconfigure whenever memory is cleared.

(See Mode 5, CONFIGURE for the consequences of clearing memory.)

1 = ADD/CHANGE FORMULA

When the display = PROGRAM 1 MENU
ADD/CHANGE FORMULA



ADD/CHANGE FORMULA
00

If selected formula doesn't yet exist, "ADD" blinks; if it does, "CHANGE" blinks.

To Access a Formula

= Formula 08 (example). Selects formula number. 01 - 98 available.

or Scrolls the unused formula numbers.

+ or + Scrolls the existing formulas.



Accesses selected formula.

Display = F08 FORMULA 08
S01

(example: Formula 08 now available for add or change/delete. Formula name can now be changed - up to 16 characters).

To Name The Formula

Names the formula the same as the formula number, or

* enters "SHIRTS" (example)

* Example: For "H", press twice or hold it to scroll. (Zero key displays a blank.)

or Moves cursor right/left.



Accepts formula name.

Display = F08 FORMULA 08
S01 00 STEP 01

To Select a Step Name

Names this step the same as the step number, or

Selects prenamed step name 05.(example). 01 - 15 available.

See Mode 3, CHANGE STEP NAMES.

or Scrolls the 15 prenamed step names.

Returns the cursor to formula name (only if this is step 01).



Accepts step name.

Display = F08 TMMQCCCHC3B LS
S01 0000-----

If this is an existing formula, and the cursor is not showing, see next page to delete this step or to duplicate a bath step.

To Delete or Duplicate a Step

CANCEL + **ENTER** Deletes this step. The next higher step becomes the current step. The control prevents deleting an END FORMULA or a bath between two extracts.

EXTEND + **ENTER** Duplicates this step. If this is step 1, the duplicated step becomes new step 1 and all the following steps move one number higher. The control prevents duplicating an END FORMULA or an EXTRACT.

ENTER Advances cursor (without deleting or duplicating this step).

Display =

| |
|-----------------------|
| F01 TMMQFFFHC3B LS |
| S01 0 0 0 0 - - - - - |

The first Page B decision is
T = TYPE OF STEP
(Details later herein).

To Delete an Existing Formula

Enter T=0 (TYPE OF STEP=END) in step 01

How the Formula Programming Help Screens Work

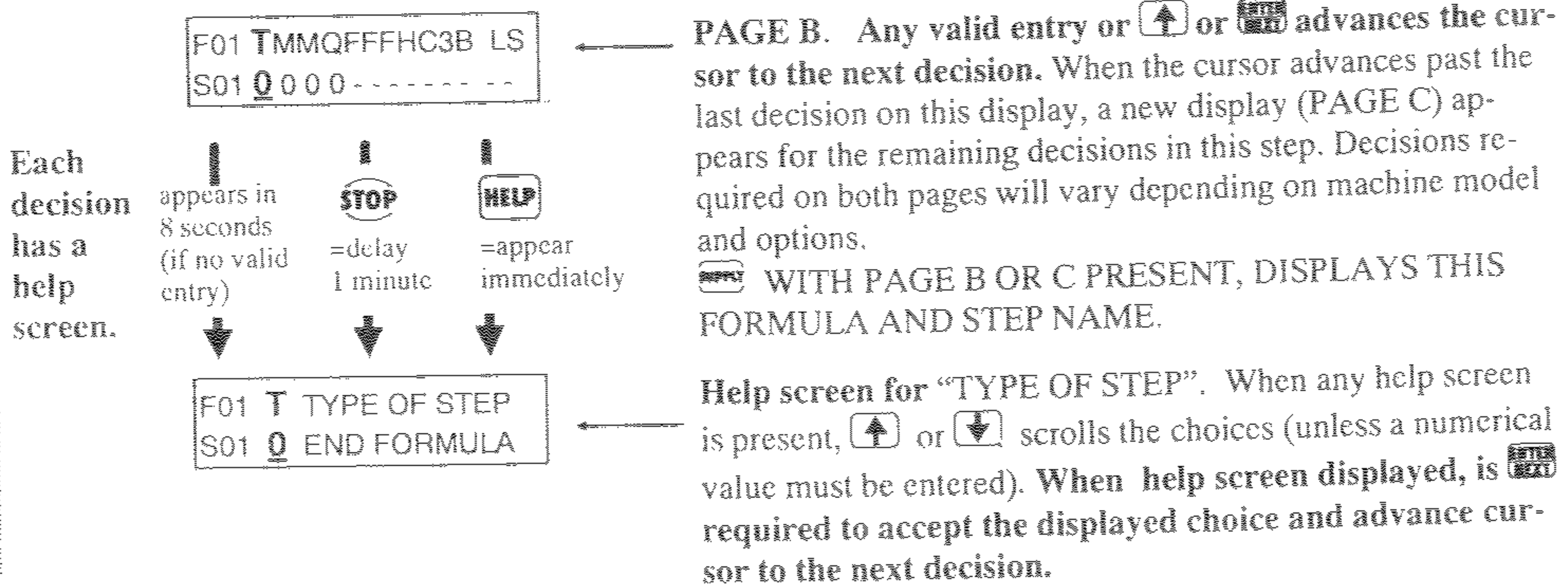

See "To Move Cursor Backward/Forward in Formula Programming", next page.

To Move Cursor Backward / Forward In Formula Programming

Each step has 3 successive displays—pages A, B and C.

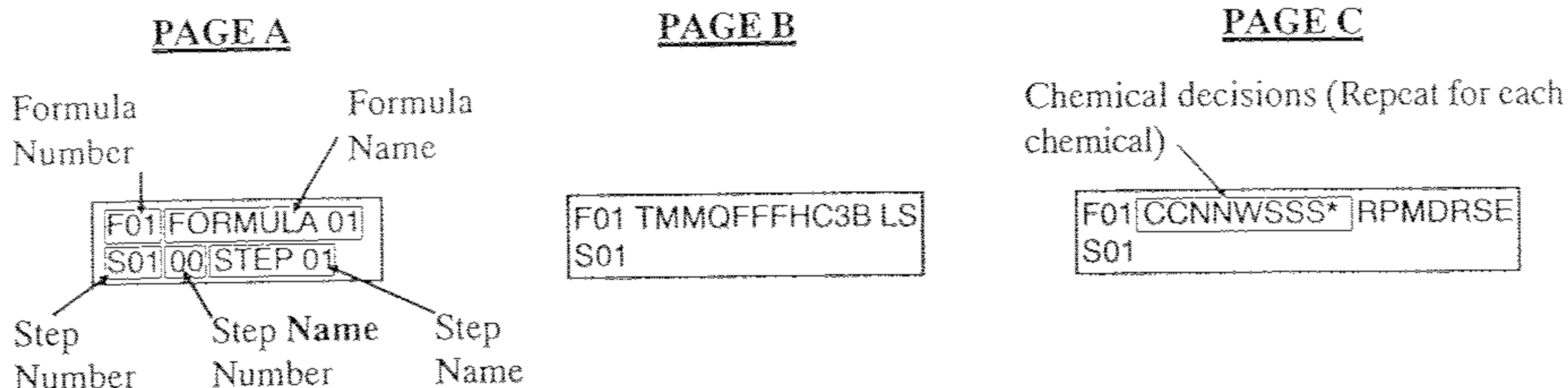

If page A, B, or C is displayed (but not the help screen) and the cursor is blinking:



Moves the cursor backward among the three pages, through each valid decision within a specific step, except—

- If this is step 1 and the cursor is at decision T on page B, it will back up to Formula name. If this is not step 1, the cursor will back up to Step name number.
- If the cursor is at any chemical decision on page C, it will not back up to page B or to the chemical decisions for a previously commanded chemical in this bath.
- If the cursor is beyond the chemical decisions on page C, it will back up to the **first** decision (CC) for the **first** chemical commanded in this bath (if any) and then to page B.



or



Moves the cursor forward among the three pages through each valid decision in a specific step. This accepts the “standard” or “default” decision if another choice was not previously made.

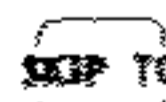

+



Scrolls backward to the beginning of each previously programmed step.

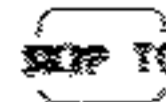

+



Scrolls forward to the beginning of each previously programmed step.

The Decisions When Programming a Step

TMMQFFFHC3B LS

A total of 98 formulas with a total of 499 steps may be programmed.

T = Type Of Step

0 = End Formula

(The last step must be 0 = END FORMULA and is automatically added as a last step if 4, 6 or 7 is selected.) The formula can be ended without an extract by making T=0 in the last step. An existing formula will be deleted if T=0 in step 01. Step 01 may not = 4, 5, 6, or 7.

1 = 1-Way Wash

Increases mechanical action. Use for small pieces which cannot tangle.

2 = 2-Way Wash

Use for sheets or other large pieces which tangle unless reversed.

3 = Soak Wash

(CYLINDER DOES NOT TURN) Use for delicate fabrics.

4 = Pre+final
Extract

Minimum time = 180 seconds. Extracts for 90 seconds, then timer stops while cylinder stops, jogs and, redistributes; then final extracts (with a 90 second low speed extract before accelerating to E2 if the machine has E1 and E2) for the remaining commanded extract time. Use only with goods that tend to stick, as this function may cause unwanted extract recycles.

5 = Intermediate
Extract

For extracts between baths or for final extract at low (E1) speed only when machine has two-speed extract.

6 = Final
Extract

E1 duration dictated by CONFIGURE decision (see Mode 5 = CONFIGURE) then E2 for remainder of commanded extract time.

7 = Double
Extract

Minimum time = 180 seconds. Use with mats to purge entrapped water. Extracts for 90 seconds (at low speed if machine has 2 speed extract, or at 50% if machine has variable speed extract) then timer stops as machine brakes to run at drain speed for 30 seconds then reenters extract for the remaining commanded time.

TMMQFFFHC3B LS

MMQ = Duration of step in minutes, minutes and quarters of minutes

0 0 1 = 00.25 minutes (i.e., 00 minutes and 15 seconds - minimum)

0 1 0 = 01.00 minutes (inserted if this decision ignored).

1 1 3 = 11.75 minutes (i.e., 11 minutes and 45 seconds - example)

6 3 3 = 63.75 minutes (i.e., 63 minutes and 45 seconds - maximum)

TMMQFFFHC3B LS

§ If machine has temperature control

FFF = °F commanded in this bath if configured for °F

CCC = °C commanded in this bath if configured for °C

000 = No temperature commanded in this bath.

- - - = Display if no temperature commanded in this bath

050 = MIN °F (010 = MIN °C)

205 = MAX °F (095 = MAX °C)

(Must modulate at least one water valve or inject steam in this bath, otherwise cursor will return here for temperature correction)

**MACHINES WITH HOT/COLD/(3RD)
WATER VALVES**

TMMQFFFHC3B LS

+H = Hot water valve
0 = OFF
1 = ON
2 = Raises temp of filling water
@3 = Not allowed

TMMQFFFHC3B LS

+C = Cold water valve
0 = OFF
1 = ON
2 = Not allowed
@3 = Lowers temp of filling water

TMMQFFFHC3B LS

+3 = 3rd water valve
0 = OFF
1 = ON
@2 = Raises temp of filling water
@3 = Lowers temp of filling water

**MACHINES WITH COLD/2ND/(3RD)
WATER VALVES**

TMMQFFFC23B LS

+C = Cold water valve
0 = OFF
1 = ON
2 = Not allowed
3 = Not allowed

TMMQFFFC23B LS

+2 = 2nd water valve
0 = OFF
1 = ON
2 = Not allowed
3 = Not allowed

TMMQFFFC23B LS

+3 = 3rd water valve
0 = OFF
1 = ON
2 = Not allowed
3 = Not allowed

How to Command a FIRST "Bath" Without Water to Shake Sand and Dirt out of Walk-Off Mats.

Command O = "OFF" for all water valves, and Liquor Level = 0 (no water in this bath). This feature is only available in the first "bath".

How to Modulate Water Valves to Regulate the Temperature of Incoming Water

@ When a thermo-modulated temperature of the incoming water is commanded in a machine having both hot and cold water valves, a faster, more accurate fill with fewer temperature swings will occur with H=1 (hot=ON) and C=3 (Cold lowers fill temp) when the commanded temp is hotter than "split" or with H=2 (Hot raises fill temp) and C=1 (Cold=ON) when the commanded temp is colder than "split." Use H=2 (Hot raises fill temp) and C=3 (Cold lowers fill temp) when temperature is near "split" or when in doubt. Although 2 is not allowed for cold and 3 is not allowed for hot water, both 2 and 3 are allowed for 3rd water, since 3rd water may be either hot or cold.

NOTE: This system can only regulate the average temperature of the incoming water. The actual final bath temperature - before adjustment by supplemental steam injection (if available) will be influenced by both the temperature of the preceding bath and the relationship of the hot and cold water temperatures and pressures vis - a - vis the desired temperature.

TMMQFFFHC3B LS

§ If machine has spray rinse

B = Bottom fill? (if machine has spray rinse through the door)

0 = NO. Fill through door

1 = YES. Fill thru bottom (mandated with thermo modulated water if only one temp probe)

TMMQFFFHC3B LS

In 3-level machines, bath level 2 is mandated prior to any extract.

L = Liquor level

0 = No water in this bath. Used to first shake dry soil out of mats. Provided "DO NOT DRAIN" is not commanded for this bath's drain, when the drain valve opens at the end of this bath, the cold water valve also opens for the time stipulated in the "DRAIN WASH OUT" CONFIGURE DECISION SS (or for the drain time, whichever is shorter) to flush out loose, dry soil.

1 = Level 1

2 = Level 2

3 = Level 3

How to Cooldown

A cooldown is programmed as a separate bath step following the bath in which the Cooldown is desired. In this Cooldown step, command a Cooldown temperature, plus **0** in each water valve, plus **any** liquor level. The control will automatically insert a "no drain" in the previous bath and **010** in **MMQ**; (a Cooldown cannot be commanded following an extract.) Cooldown will proceed at the commanded liquor level for 1 minute after temperature is achieved, whereupon the machine will drain (unless no drain is commanded to prolong this Cooldown bath when desired, as to add chemicals after achieving the Cooldown temperature). If 0(zero) is commanded for each water valve in a bath following an extract:

NOTE: The commanded Cooldown temperature must always be about 15-20° (8-11°C) higher than the hottest ambient temperature **or** the hottest cold water temperature that will be encountered, or it may take a long time or even be impossible to achieve.

Display = Fxx COOLDOWN ILLEGAL
Sxx PRESS NEXT



Returns the cursor to the first Water Valve decision.

TMMQFFFHC3B LS

§ If machine has steam.

S = Steam in this bath

0 = No steam

| | EARLY | AFTER | TIMER |
|----------|-------|-------|-------|
| 1 | = No | Yes | Runs |
| 2 | = No | No | Stops |
| 3 | = No | Yes | Stops |
| 4 | = Yes | Yes | Runs |
| 5 | = Yes | No | Stops |
| 6 | = Yes | Yes | Stops |

See How to Select the Steam Code, next page

How to Select the Steam Code

EARLY = YES starts steaming at lowest level. Use "YES" when machine has only cold water valve or when plant has only low-temperature hot water. "NO" starts steaming when commanded level achieved. Use "NO" when machine has both hot and cold water valves if commanded temperature is lower than hot water temperature.

AFTER = YES resumes steam in this bath if temperature falls below commanded, once initially achieved. "NO" prohibits further steam once temperature is achieved. Use "NO" if chemicals or goods may be injured by steam after chemical injection (as in bleach baths), otherwise use "YES".

TIMER RUNS while steaming or **STOPS** until temperature first achieved. Use "RUNS" if temperature need not be exactly maintained throughout bath and/or when it is certain that commanded temperature will be nearly achieved while filling. Use "STOPS" if temperature must be achieved before adding chemicals, otherwise software will suppress this chemical-add choice.

CCNNWSSS*RPMDRSE

Page C. Any valid entry or  advances the cursor to the next decision. If optional CHEM-WAIT (CHEMSAVE) is functioning on this machine, during operation, when a chemical injection is called for the machine timer will stop in response to a "WAIT" signal from the chemical system. Refer to "How 'CHEMWAIT' works . . ." (see Table of Contents).

§ Number of chemicals depends on specific machine

CC = Chemical number (or signal without chemical)

00 = No chemicals in this bath; cursor advances to next decision.

02 = Chemical 02 (01 - 15 available if machine is so equipped).

16 = Signal without chemical



In help screen, accepts chem number (CC) and name (NN); advances cursor to W.

CCNNWSSS*RPMDRSE

NN = Chemical name

00 = Names the chemical the same as the chemical number. (example: CHEMICAL 05)

25 = Prenamed chemical name 25 (01 - 63 available. See MODE 4, CHANGE CHEM NAMES)

 or  Scrolls the prenamed chemical names.

CCNNWSSS*RPMDRSE

W = When to start chemical injection

0 = With fill

1 = Level ok

2 = Level+temp ok (This choice is not available unless steam injection to a specified temperature with "TIMER STOPS WHILE STEAMING" is commanded.)

CCNNWSSS*RPMDRSE

SSS = Seconds of chemical injection

001 = 1 Second - minimum inject time (automatically inserted if this decision is ignored)

127 = 127 seconds - maximum inject time (automatically inserted if any higher number entered)

CCNNWSSS*RPMDRSE

*** = Signal with chemical**

0 = NO

1 = YES

The signal will not occur until the "WHEN TO START CHEMICAL INJECTION" command has been satisfied and the commanded chemical inject will not start until the signal is cancelled

CCNNWSSS*

Add another chemical in this bath, if desired.

00 ANOTHER CHEM?

00 = No additional chemicals in this bath; cursor advances to next decision

03 = Chemical 03 (or any other valid chemical number). Returns to decision **NN** above.

16 = Signal without chemical

CCNNWSSS*RPMDRSE

§ If machine has variable speed wash and/or variable speed extract

RPM = Basket speed in this step as % of normal

015 = 15%—Minimum allowable wash (all except FxP models)

050 = 50%—Minimum allowable wash (FxP only)

120 = 120%—Maximum allowable wash

025 = 25%—Minimum allowable extract

100 = 100%—Maximum allowable extract

As of this writing variable speed extract is available only on FxP models.

CCNNWSSS*SPDRSE

§ If machine has two speed wash

SPD = Basket speed in this step - normal or low speed

-- **0** = Normal speed

-- **1** = Low speed

CCNNWSSS*RPMDRSE

This decision affects basket rotation during draining and the **previous** fill. Since the machine must enter extract from drain (distribution) speed, if the next step is an extract, the control automatically changes a selected 1, 2, or 3 to 0; or a 5, 6, or 7 to 4.

D = Drain type

0 = Standard drain speed

Basket turns clockwise at drain (distribution) speed.

1 = Two way wash speed

Wash speed, reversing; more mechanical action while draining.

2 = Do not drain

Use for functions later in this bath, such as to inject chemicals, raise temperature or level or change basket speed without draining.

3 = Stop with drain

Basket stationary; no mechanical action while draining.

4 = Stop with fill

Basket stationary during **previous** fill; drain speed while draining.

5 = Stop with fill and drain

Basket stationary during draining and **previous** fill.

6 = Stop with fill and no drain

Basket stationary during **previous** fill; no drain.

7 = Drain with 25 second spray rinse

(sprays for the last 25 seconds of **drain** if machine has spray rinse)

CCNNWSSS*RPMDRSE

§ If machine has reuse drain

R = Drain destination

0 = Drain to sewer

1 = Drain to reuse

CCNNWSSS*RPMDRSE

§ If machine has spray rinse

S = Spray rinse (Sprays for the last 25 seconds of **extract** if machine has spray rinse **and** this is an intermediate extract)

0 = NO

1 = YES











F01 FORMULA 01
S02 00 STEP 02

Advances to **page a** of next step (repeat applicable decisions for each step) or advances to **"E"** (see next page) if this is the final extract, or if the formula is ended without an extract by commanding T=0 in the last step.



CCNNWSSS*RPMDRSE

When the formula ends with a bath, only end codes 0, 1, and 2 are available. When the formula ends with an extract, an additional "end step" is added automatically.

E = How to end?

- 0 = Stopped Operator presses  or  to silence the signal.
- 1 = Reversing (at wash speed)—Operator presses  or  to END.
- 2 = Drain speed Operator presses  or  to END.
- 3 = Break cake Basket takes a series of actions for 3 minutes then stops. Use to loosen goods that remain plastered to the basket after formula ends. Operator presses  or  to silence the signal.
- 4 = Tumbling Similar to REVERSING except press STOP button to stop the cylinder and permit door to open so any stuck goods can be pulled down. After closing door, press  to continue tumbling. Operator signal recurs after 2 minutes. Press  or  to END.

PROGRAM 0 MENU
OK TURN KEY TO RUN

This display reappears. Select  to add/change another formula or select any other mode in the Program Menu or ,  to return to the Run Mode.

How to Create an Overnight Bath Soak

In the first bath step, command T=3 (Type of Step=Soak Wash), MMQ=600 (Duration of step=1 hour), D=2 (Drain type=do not drain), and all other decisions as desired. Then, simply duplicate this step as many times as hours of soak are desired. Remember to add a last step with a T=0 (END FORMULA) command.

If chemicals will be injected automatically in the first bath and if the "duplicate step" command is used to create the additional steps, remember to delete the chemical injections from the additional steps unless the chemical injections are actually desired in every additional step.

Power and air pressure must remain on as long as this "overnight soak" formula is running.

2 = COPY OLD TO NEW

When the display =

| |
|-----------------------|
| PROGRAM <u>2</u> MENU |
| COPY OLD TO NEW |

| |
|---------------|
| ENTER NEXT |
| = |
| COPY SOURCE |
| <u>00</u> |

| |
|---|
| ↑ |
|---|

 or

| |
|---|
| ↓ |
|---|

 Scrolls the existing formula numbers.

05 = Formula 05 (example). Selects formula to be copied.

If this formula does not exist.

Display =

| |
|--------------------------|
| COPY SOURCE |
| <u>05</u> DOES NOT EXIST |

This display remains on the screen, permitting any other formula number to be entered.

If this formula does exist.

Display =

| |
|------------------|
| COPY SOURCE |
| <u>05</u> SHIRTS |

(example)

| |
|------------------|
| ENTER NEXT |
| = |
| COPY DESTINATION |
| <u>00</u> |

| |
|---|
| ↑ |
|---|

 or

| |
|---|
| ↓ |
|---|

 Scrolls the unused formula numbers.

12 = Formula 12 (example). Selects formula to be created.

If this formula already exists.

Display =

| |
|-------------------|
| COPY DESTINATION |
| 12 ALREADY EXISTS |

This display remains on the screen, permitting any other formula number to be entered.

If this formula does not exist.

Display =

| |
|------------------|
| COPY DESTINATION |
| 12 FORMULA 12 |

| |
|-----------------------|
| ENTER NEXT |
| = |
| PROGRAM <u>0</u> MENU |
| OK TURN KEY TO RUN |

The selected existing formula has been copied into the selected, unused formula number, except that the existing formula name was not copied. (In the example, the new formula name is "FORMULA 12".)

3 = CHANGE STEP NAMES

The following standard English Step Names were supplied with the control. Whenever MEMORY IS CLEARED, these standard step names (or their foreign language equivalents) will reappear and all field-changed step names will be erased and lost.

AVOID DATA LOSS

The control must always be CONFIGURED for the desired language (English or Foreign) before changing any step name. Step names 01 through 12, if field-changed, will be erased and lost whenever the language decision in CONFIGURE is changed, even though MEMORY IS NOT CLEARED.

| | | | | | | | | | | | | | |
|--|------------|------------|-----------|-------------|------------|----------------|-----------|---------------|---------------|----------------|-------------|-------------|-------------------|
| 00 NAMES THE STEP THE SAME AS THE STEP STEP NUMBER AND CANNOT BE CHANGED | 01 = FLUSH | 02 = BREAK | 03 = WASH | 04 = BLEACH | 05 = RINSE | 06 = ANTICHLOR | 07 = SOUR | 08 = SOURSOFT | 09 = SOFTENER | 10 = MILDICIDE | 11 = FINISH | 12 = STARCH | 13 - 15 = NAME ME |
|--|------------|------------|-----------|-------------|------------|----------------|-----------|---------------|---------------|----------------|-------------|-------------|-------------------|

When the display = PROGRAM 3 MENU
CHANGE STEP NAMES ENTER
NEXT = CHANGE STEP NAMES
01 FLUSH

03 = WASH (example). Selects a step name number. 00 - 15 available.

↑ or ↓ Scrolls the step names.

ENTER
NEXT Accesses the selected step name.

Display = CHANGE STEP NAMES
03 WASH (example: Step name 03 can now be changed - UP TO 8 CHARACTERS.)

↑ or ↓ Moves the cursor right/left (within the 8 character step name field).

S, ↑, U *, ↑, D, ↑, S enters "SUDS" (example)

* example: For "U", press 7
STB 3 times or hold it to scroll. (Zero key displays a blank.)

ENTER
NEXT Accepts the displayed step name.

Display = CHANGE STEP NAMES
04 BLEACH (example) Select this or another step name to change, or exit this mode.

ENTER
NEXT Accesses the displayed step name, or

ESCAPE Exits this program mode.

Display = PROGRAM 0 MENU
OK TURN KEY TO RUN

4 = CHANGE CHEM NAMES

The following standard English Chemical Names were supplied with the control. Whenever MEMORY IS CLEARED, these standard chemical names (or their foreign language equivalents) will reappear and all field-changed chemical names will be erased and lost.

AVOID DATA LOSS

The control must always be CONFIGURED for the desired language (English or Foreign) before changing any chemical name. Chem names 01 through 15, if field-changed, will be erased and lost whenever the language decision in CONFIGURE is changed, even though MEMORY IS NOT CLEARED.

| | | | |
|-------------------|----------------------------|----------------------|----------------------|
| 00 NAMES THE CHEM | 01 = ALKALI | 06 = CHLORINE BLEACH | 11 = SOUR + SOFTENER |
| THE SAME AS THE | 02 = SOAP | 07 = OXYGEN BLEACH | 12 = STARCH |
| CHEM NUMBER | 03 = DETERGENT | 08 = ANTICHLOR | 13 = ANTI-MILDEW |
| AND CANNOT BE | 04 = SOAP + ALKALI | 09 = SOUR | 14 = ANTI-BACTERIA |
| CHANGED | 05 = DETERGENT + ALKALI | 10 = SOFTENER | 15 = FINISHING CHEMS |
| | | | 16-64 = CHEM NAMExx |

Any chemical name can be assigned to any chemical injection or to any signal without chemicals.

When the display = PROGRAM 4 MENU
CHANGE CHEM NAMES ENTER
NEXT = CHANGE CHEM NAMES
01 ALKALI

13 = ANTI-MILDEW (example). Selects a chem name number. 00 - 64 available.

↑ or ↓ Scrolls the chem names.

ENTER
NEXT Accesses the selected chemical name.

Display = CHANGE CHEM NAMES
13 ANTI-MILDEW (example: Chem name 13 can now be changed-UP TO 15 CHARACTERS.)

↑ or ↓ Moves the cursor right/left (within the 15 character chem name field).

M, ↑, I*, ↑, L, ↑, D, ↑, I, ↑, S, ↑, T, ↑, A, ↑, T enters "MILDISTAT" (example)

* example: For "I", press I 3 times or hold it to scroll. (Zero key displays a blank.)

ENTER
NEXT Accepts this displayed chem name and displays the next higher chem name.

Display = CHANGE CHEM NAMES
14 ANTI-BACTERIA

(example) Select this or another chem name to change, or exit this mode.

ENTER
NEXT Accesses the displayed chem name,

or ESCAPE Exits this program mode. Display = PROGRAM 0 MENU
OK TURN KEY TO RUN

5 = CONFIGURE (AND WHY IT IS NECESSARY)

Because the microprocessor can control several different models, it is necessary to "CONFIGURE" each unit to match its specific model and type washer extractor, including such optional features as the number of water and chemical valves, whether or not the machine has thermostatically controlled water and/or steam temperatures, Cool-down, multispeed or variable speed motors, MILDATA, etc. Such decisions are discrete to the specific machine and must never be changed unless options are later added or removed. However, certain other CONFIGURE decisions, such as whether to display English or metric units, English or non-English messages, whether or not a password is required for manual intervention (and for changing the password itself) may be subsequently changed if desired.

If power is turned off while in Program Menu 5, the control powers up in the Configure Mode and must be reconfigured.

WHEN TO RECONFIGURE AND WHAT CONFIGURE CODES TO USE

Reconfigure at installation and any time memory is cleared. although certain codes are discretionary and are so marked below, most CONFIGURE CODES MUST match those shown on the Metal Configure Nameplate, Unless optional equipment has been added to or removed from the machine.

When the display =

PROGRAM **5** MENU
CONFIGURE



**ENTER
NEXT**

ABCDEFGHIJKLMNOPQRST
00000000000000000000

CONFIGURE, PAGE AA (decisions A-T) shown. A = TEMP UNITS

To Move The Cursor Backward And Forward In Configure

In the first two CONFIGURE pages (AA and BB) and if the help file is **not** displayed (see next page for how the CONFIGURE help screens work)—

 or  Moves cursor forward or backward between pages aa and bb, retaining each previously entered choice.

Page AA

ABCDEFGHIJKLMNOPQRST
Q0000000000000**00000

Page BB

UVWXYZ
000000

**ENTER
NEXT** or valid choice required in last Page BB decision to continue to the next display.

Several other displays that move forward only follow Page BB. In any CONFIGURE display-

**ENTER
NEXT** Moves cursor forward among all pages and valid decisions.

How The Configure Help Screens Work

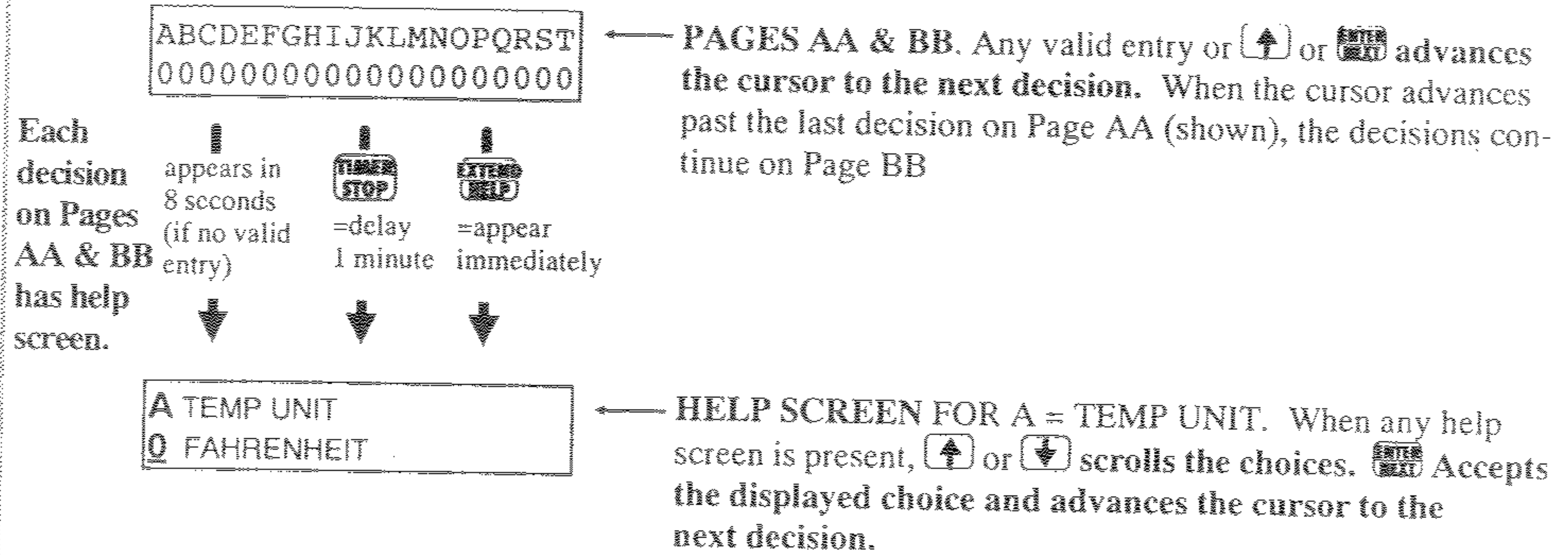

A TEMP UNIT
1 CENTIGRADE

D 0 = FAHRENHEIT
1 = CENTIGRADE

B LANGUAGES
0 ENGLISH

D 0 = ENGLISH Machine supplied with one customer-specified non-English language.
1 = FOREIGN

AVOID DATA LOSS

If Step or Chem names have been field programmed, these may be deleted and lost if the previously programmed language choice is changed now. See "Mode 3 = CHANGE STEP NAME" and "Mode 4 = CHANGE CHEM NAME" herein for more information.

C FXP MACHINE
0 NO

0 = NO FxP (foundationless body style) machines have the nameplate model designation xxxxx-
1 = YES FxP. example: 36021F8P.

D EXTRACT SPEEDS
0 1 EXT SPEED

0 = 1 EXTRACT SPEED
1 = 2 EXTRACT SPEEDS

E STAPH GUARD
0 NO

0 = NO STAPH GUARD machines have the nameplate model designation xxxxxSPx. example:
1 = YES 60044SP2.

F ANTI-PLUG
0 1.7 SECS

0 = 1.7 SECONDS 2 = 2.3 SECONDS
1 = 2.0 SECONDS 3 = 3.2 SECONDS

This is dwell time between wash motor OFF and restart in reverse direction.

AVOID EQUIPMENT DAMAGE

Never select an "F" code that yields a shorter dwell time. A longer dwell time may be substituted if desired. Shorter dwell times may damage wash motor or belt/gear train.

D = discretionary. All other CONFIGURE CODES are discrete to, and must match, the specific machine.

DRAIN **G** BTH EXT E1-2
(SEC) 0 30 30 45

| | BATH | EXTR | E1-E2 | BATH | EXTR | E1-E2 |
|----------|------|------|-------|----------|------|-------|
| 0 | = 30 | 30 | 45 | 4 | = 90 | 90 |
| 1 | = 45 | 45 | 60 | 5 | = 90 | 120 |
| 2 | = 60 | 60 | 90 | 6 | = 30 | 60 |
| 3 | = 75 | 75 | 105 | | | |

This is drain time in seconds after each BATH or before each EXTRACT, and also the delay time from E1 to E2 (low to high speed extract) if machine has 2 speed extract.

WHAT CONFIGURE "G" CODE TO USE?

Never select a "G" code number that yields a shorter drain or E1/E2 delay time. Only longer drains and/or longer E1/E2 delay times may be substituted should the installation drain system warrant. Shorter times may not permit a full drain before the onset of extraction. This could damage the E1 motor or not permit sufficient drain/acceleration time between E1 and E2, therefore possibly damaging the E2 motor.

H STEAM ERROR
1 5 MIN

- 0** = NO STEAM
- D 1** = 5 MINutes
- D 2** = 10 MINutes
- D 3** = 50 MINutes

Permits steaming for time indicated before "TOO LONG TO STEAM" error is displayed. Choose **0** if machine has no steaming function.

I FILL ERROR
0 3 MIN

- D 0** = 3 MINutes
- 1** = 5 MINutes
- 2** = 10 MINutes
- 3** = 15 MINutes

Permits filling for time indicated before "TOO LONG TO FILL" error is displayed.

COOLDOWN **J** ERROR
1 5 MIN

- 0** = NO COOLDOWN
- D 1** = 5 MINutes
- D 2** = 10 MINutes
- D 3** = 20 MINutes

Permits Cooldown for time indicated before "TOO LONG TO COOL" error is displayed. Choose **0** if machine has no Cooldown function.

WATER OPT **K**
H+C 0

- 0** = HOT + COLD water valves (standard USA version)
- 1** = COLD + 2ND water valves (STD. - EUROPE/OVERSEAS)
- 2** = HOT + COLD + 3RD water valves
- 3** = COLD + 2ND + 3RD water valves

REUSE OPT **L**
NO 0

- 0** = NO
- 1** = YES

Reuse means machine can drain either to sewer or to reuse.

SPRAY OPT **M**
0

- 0** = NO SPRAY
- 1** = SPRAY RINSE (for certain open pocket machines)
- 2** = SPRAY DOWN (for certain two pocket machines)

CONFIGURE codes **N** AND **O** not currently used.

D = discretionary. All other CONFIGURE CODES are discrete to, and must match, the specific machine.

| | | |
|---|--|--|
| BALANCING OPT P <u>0</u> | 0 = NO 1 = YES | Does machine have "hydraulic (water) balancing" feature? |
| BWP Q NO <u>0</u> | 0 = NO 1 = YES | |
| TWO SPEED WASH R NO <u>0</u> | 0 = NO 1 = YES | (when wash motor has two specific wash speeds—not to be confused with variable speed wash) |
| AMPSAVER OPT S NO <u>0</u> | 0 = NO 1 = YES | Optional feature to limit maximum amperes required by a battery of machines. |
| TEMP PROBES T 1 TEMP PROBE <u>1</u> | 0 = NO TEMP PROBE 1 = 1 TEMP PROBE 2 = 2 TEMP PROBES | Number of probes depends on model and method of filling with water. |

CONFIGURE CODES **U** and **V** not currently used.

| | | |
|--|---|--|
| W VARIABLE WASHSPD <u>1</u> VARIABLE SPEED | 0 = NO VARIABLE SPEED 1 = VARIABLE SPEED | (for variable wash speed only—not to be confused with "FXP" or two speed wash) |
| X MANUAL PASSWORD <u>1</u> YES | 0 = NO—No password required for manual modifications to a running formula. 1 = YES—Password required | |

The following decision required only if Decision X (MANUAL PASSWORD) = 1 (YES).

| | |
|-----------------------------|--|
| PASSWORD: <u>a b c d</u> | D a b c d is any four digit number. Control defaults to 1 2 3 4 if power is turned off while in configure. |
|-----------------------------|--|

CONFIGURE CODES **Y** and **Z** not currently used.

| | | |
|--------------------------------|-------------------------|--|
| # OF CHEM VALVES: <u>05</u> | 00 - 15 allowed | Must enter number. Cannot scroll |
| DRAIN WASH OUT SS 45 | 00 - 45 seconds allowed | If a no-water bath is commanded (to shake out loose, dry soil) and provided "DO NOT DRAIN" is <u>not</u> commanded for a bath's drain, when the drain valve opens at the end of the bath, the cold water valve also opens for the time stipulated here (or for the drain time stipulated in Configure decision G, whichever is shorter) to flush out the soil. |

| | | |
|--|--|--|
| MACHINE NAME <u>64042BTN MACHINE 07</u> | Any name (up to 20 characters) to identify this machine. Name appears on print-outs when Program Menu, Mode 8: "PRINT DATA" is used. | |
|--|--|--|

If this machine is not part of a MILNET or MILTRAC system, the following decision is meaningless, press .

| | | |
|------------------------------|-------------------|---|
| MILNET ADDRESS <u>000</u> | 000 - 255 allowed | Must enter number; cannot scroll. See also MILNET/MILTRAC technical manual. |
|------------------------------|-------------------|---|

D = discretionary. All other CONFIGURE CODES are discrete to, and must match, the specific machine.

SIMULATOR VERSION ?
1 YES

0 = NO
1 = YES

Select 1 = YES only if this is a simulator. If YES, board will not operate a washer extractor or any outputs, but the simulator can send data to a printer or download to a machine or tape.

MILDATA ?
1 YES

0 = NO—Machine does not communicate with MILDATA
1 = YES—Machine communicates with MILDATA

The following decisions required only if **MILDATA = YES**.

MILDATA ADDRESS ?
170

000 - 255 Allowed.

Must enter number; cannot scroll. See also MILDATA technical manual.

DATA ENTRY FWGCE
01 000

FORMULA
WORK ORDER
GOODS CLASS
CUSTOMER
EMPLOYEE
FWGCE

Must enter 0 = NO or 1 = YES under each data entry type allowed by the control. Cannot scroll or move backwards.  accepts each choice and advances to the next data entry type. See also MILDATA technical manual.

1 0 0 0 0 = Data entry by formula only. (example)

- 1 0 0 # # 1. Control will only accept combinations shown at left.
- 0 1 0 0 # 2. Cursor will skip over any choice if dictated by a previous choice.
- 0 0 1 # # 3. # indicates can be either 0 or 1.

6 = DOWN LOAD

Downloading transfers all formulas, step-names, chem names, configure codes (if specified), programming prompts, and run display messages from one machine (or simulator or PC) to another via a serial communication cable or between a machine and cassette tape via a MILNOR Cassette Tape Interface. Downloading eliminates the need to enter the same data repeatedly.

General Rules For Downloading

1. Downloading completely replaces all of the above mentioned data (configure codes will be down loaded only if specifically commanded). Selective downloading (example: transferring only certain wash formulas) is not possible.
2. Valid downloading requires that the sending and receiving machines have the identical software version and that the receiving machine's model and options closely correspond to the sending machine's configuration. The following conditions produce data that is valid for the receiving machine(s) to the extent indicated:
 - Downloaded data is fully valid when all the machines have identical software version, and all receiving machines match the sending machine's configuration (model and options).
 - Identical software version, sending machine's configuration matches receiving machine's model but not it's options - Modify configure codes and formulas to suit receiving machine's options. Generally, only minor corrections are required to validate data after downloading, thus down loading is usually beneficial.
 - Identical software version, but configuration does not match receiving machine's model - Formulas usually require substantial modification to validate the data, thus, downloading is of questionable value.
 - DO NOT DOWNLOAD DIFFERENT SOFTWARE VERSIONS. (Will result in scrambled, unusable data.)

▲ CAUTION ▲

Unless all machines have IDENTICAL configurations, after down-loading, always reconfigure in accordance with each receiving machine's configuration nameplate. failure to do so may compromise safety and result in damage to goods or machine.

3. For machine to machine transfers where a serial link is not permanently installed (in conduit) between the participating machines, install a temporary cable in accordance with "HOW TO INSTALL SERIAL LINKS" elsewhere in this manual.

AVOID DATA LOSS

Remove temporary cable as soon as downloading completed.

GENERAL RULES FOR DOWNLOADING, CONTINUED

4. Do not use the downloading procedures described herein with machines that are part of a MILTRAC, MILNET or MILDATA system unless all system devices except those participating in downloading are turned off. Download data and system data share the same serial communication line, thus download data can disrupt system operation and system data can scramble the download data.

NOTE: This restriction does not apply to downloading from a MILDATA computer. See procedures for downloading with MILDATA in the MILDATA technical manual.

5. Downloading to/from tape requires the MILNOR Cassette Tape Interface. Connect the appropriate lead from the interface box to the Download jack on the machine. Connect the other lead from the interface box to the tape recorder. Set the cassette tape recorder and the Cassette Tape Interface Box as follows:

| Type of Transfer | Toggle Switch on Interface Box | Tape Recorder |
|------------------|--------------------------------|--|
| machine to tape | TO TAPE | 1. connector from interface box plugged into microphone jack 2. blank tape loaded, fully rewound |
| tape to machine | TO MACHINE | 1. connector from interface box plugged into earphone jack 2. data tape loaded, fully rewound 3. volume control to maximum |

6. In the downloading process there may be one or more slave (receiving) machines or one receiving tape recorder and only one master (sending) machine or tape recorder. **Designate all slave (receiving) machines first. If data is transferring between machines, down loading begins as soon as one machine is designated as the master.** If transferring from machine to tape, down loading begins 10 seconds after the machine is designated the master. If transferring from tape to machine, downloading begins when the tape recorder is set to "PLAY".
7. If data transfer is halted while sending, all receiving devices will contain a mixture of old and new data. REPEAT THE DOWNLOAD PROCEDURE.

When the display = PROGRAM 6 MENU
DOWN LOAD  = DOWN LOAD DEVICES
0 MACHINE<==>MACHINE

0--Tells the control this is a data transfer between machines. (Machine(s) may be washer extractors, simulator, or a PC not running MILDATA.)

1--This is a data transfer to/from tape.

2--This is a data transfer from MILDATA (on a PC) to machine(s).



Accepts the selected transfer type.

Display =

| |
|------------------|
| DOWN LOAD STATUS |
| <u>0</u> SLAVE |

0—tells the control this machine is receiving (not sending) data. All **receiving machines must be designated first.**
1—tells the control this machine is sending (not receiving) data. The **sending machine must be designated last.**



Accepts the selected down load status.

If this is a SLAVE (receiving) machine:

Display =

| |
|------------------|
| RECEIVE CONFIG ? |
| <u>0</u> NO |

0—specifies that configure codes **won't** down load.
1—specifies that configure codes **will** down load.

Since configure codes must match those shown on the configure nameplate, make the selection that is likely to most closely match the nameplate - usually **0** (don't down load configure codes) is best.



Accepts the selected choice.

If this is a machine to machine transfer,

display =

| |
|--------------------|
| (S) 9600 BAUD 000 |
| WAITING FOR MASTER |

If this is a transfer from tape,

display =

| |
|--------------------|
| (S) 0300 BAUD 000 |
| WAITING FOR MASTER |

If this is the MASTER (sending) machine and this is a machine to machine transfer:

Down loading has begun.

Display =

| |
|--------------------|
| (M) 9600 BAUD XXXX |
| TRANSFERRING DATA |

XXXX (scrolling hexadecimal number) indicates the byte location currently down loading. Downloading takes about 1 minute.

If this is the MASTER (sending) machine and the transfer is to tape:

10 second countdown begins.

Display =

| |
|--------------------|
| DOWNLOAD STATUS XX |
| 1 MASTER |

XX = seconds counting down. Prepare to begin recording.

Press "record" when count xx (above) = 02.

Display =

| |
|--------------------|
| (M) 0300 BAUD XXXX |
| TRANSFERRING DATA |

XXXX (scrolling hexadecimal number) indicates the byte location currently downloading. Downloading may take more than 10 minutes. MARK TAPE WITH MACHINE MODEL AND SOFTWARE VERSION.

If this is a transfer from tape to machine(s) and all slave (receiving) machines are "waiting for master":

Turn volume up full on the recorder then press "play" to begin downloading.

During downloading, receiving machine(s) should display:

| |
|--------------------|
| (S) 0300 BAUD XXXX |
| RECEIVING DATA |

or

| |
|--------------------|
| (S) 9600 BAUD XXXX |
| RECEIVING DATA |

XXXX (scrolling hexadecimal number) indicates byte location currently downloading.

If during downloading, any receiving machines display:

| |
|--------------------|
| (S) 0300 BAUD 000 |
| WAITING FOR MASTER |

or

| |
|--------------------|
| (S) 9600 BAUD 000 |
| WAITING FOR MASTER |

or

| |
|--------------------|
| ERROR IN CHECK SUM |
| NEXT TO PROCEED |

Down loading was unsuccessful. **Repeat the download process.**

 Aborts the down load process for any receiving machine on which it is commanded, or for all machines if commanded on the sending machine. **Repeat the down load process for any receiving machines on which down loading was aborted, otherwise the machine will contain a mixture of old and new data.**

Display =

| |
|-------------------|
| DOWN LOAD ABORTED |
| NEXT TO PROCEED |

When down loading is successfully complete,

All displays =

| |
|-------------------|
| PROCESS COMPLETED |
| NEXT TO PROCEED |

 =

| |
|--------------------|
| PROGRAM 0 MENU |
| OK TURN KEY TO RUN |

(Each device in the data transfer requires this command.)

7 = CLEAR ALL MEMORY (VOLUNTARILY)

When the display =

| |
|------------------|
| PROGRAM 7 MENU |
| CLEAR ALL MEMORY |

| |
|-------|
| ENTER |
| NEXT |

 =

| |
|---------------------|
| 4+5+6= CLEAR MEMORY |
| CANCEL = ESCAPE |

 No cursor

| |
|--------|
| CANCEL |
| ESCAPE |

 Exits this program mode without clearing memory.

AVOID DATA LOSS

The following key strokes will delete all user programmed data. If this mode has been entered accidentally, press

| |
|--------|
| CANCEL |
| ESCAPE |

 to cancel this procedure.

| |
|-----|
| 4 |
| JKL |

 +

| |
|-----|
| 5 |
| MNO |

 +

| |
|-----|
| 6 |
| PQR |

 Clears all user-programmed formulas, step names and chem names. The step names and chemical names originally supplied with the machine will reappear. Configure codes are unaffected when memory is cleared **voluntarily** but control **must** be **RECONFIGURED** after first commissioning the machine or after the display says "CLEAR MEMORY NOW".

See also "WHAT TO DO FIRST" at beginning of this manual.

8 = PRINT DATA

Program Menu, Mode 8 - Print Data prints the currently programmed formulas, configure codes, chemical names and step names on a serial printer which can be temporarily connected to the machine via a socket on the control. A mating plug to this socket is provided for the user's convenience in wiring the printer interface cable. See wiring instructions in "HOW TO INSTALL SERIAL LINKS" elsewhere in the manual.

When the display =

| |
|-----------------------|
| PROGRAM <u>8</u> MENU |
| PRINT DATA |

 =

| |
|-------------------|
| PRINT DATA |
| <u>0</u> FORMULAS |

- 0 = FORMULAS (Any specified range)
- 1 = CONFIGURE CODES
- 2 = CHEMICAL NAMES
- 3 = STEP NAMES

 or  Scrolls the choices

 Prompts for today's date.

Display =

| |
|---------------------------------|
| DATE: MM - DD - YYYY |
| <u>mm</u> <u>dd</u> <u>yyyy</u> |

Enter today's date, where *mm* is a two digit number for the month (i.e., March = 03), *dd* is a 2 digit number for the day of the month (i.e., 08) and *yyyy* is the year.

If 0 = FORMULAS was selected the following display appears; otherwise printing begins.

| | |
|-----------|-----------|
| START | STOP |
| <u>xx</u> | <u>yy</u> |

Formulas 00 and 99 are always printed. Enter the range of additional formulas to be printed, where *xx* is the starting formula and *yy* is the ending formula, inclusive.

- 01 = LOWEST FORMULA NUMBER (*yy* must be equal to or greater than *xx*)
- 98 = HIGHEST FORMULA NUMBER (*xx* must be equal to or less than *yy*)

When printing begins,

display =

| |
|-------------------|
| PRINTING |
| ** PLEASE WAIT ** |

When printing is concluded,

display returns to

| |
|-----------------------|
| PROGRAM <u>0</u> MENU |
| OK TURN KEY TO RUN |

FELLERIN MILNOR CORPORATION

W/E: 64042BTN MACHINE 7 VERSION 89002/S DATE: 09/08/1989 PAGE: 01

FORMULAS

T =TYPE OF STEP B =FILL HOW RPM=%SPEED
MMQ=BATH TIME L =LEVEL SPD=SPEED
FFF=BATH TEMP S =STEAM CODE D =DRAIN TYPE
CCC=BATH TEMP CC =CHEMICAL VALVE # R =DRAIN TO
H =HOT NN =CHEMICAL NAME # S =SPRAY RINSE ?
C =COLD W =WHEN START E =HOW TO END ?
2 =2nd SSS=INJECT TIME (SECS)
3 =3rd * =SIGNAL?

FORMULA RANGE = 00, 99, 01-10

CHEMICAL VALVES = 08

| | | | | | | | |
|-----|-----------|----|-----------|---|---|-----------------|-----------------|
| F00 | TMMQFFFHC | LS | CCNNWSSS* | D | E | FORMULA 00 | FORMULA 00 |
| S01 | 2070---10 | 2- | | 1 | - | 03=WASH | |
| | | .. | 010100600 | . | . | ALKALI | |
| | | .. | 020200600 | . | . | SOAP | |
| S02 | 2070---10 | 2- | | 0 | - | 04=BLEACH | |
| | | .. | 030610600 | . | . | CHLORINE BLEACH | |
| S03 | 2020---10 | 3- | 000000000 | 0 | - | 05=RINSE | |
| S04 | 5003----- | -- | ----- | - | - | 00=EXTRACT | |
| S05 | 2020---11 | 3- | 000000000 | 0 | - | 05=RINSE | |
| S06 | 5003----- | -- | ----- | - | - | 00=EXTRACT | |
| S07 | 2040---01 | 3- | | 0 | - | 08=SOURSOFT | |
| | | .. | 040910600 | . | . | SOUR | |
| | | .. | 051010600 | . | . | SOFTENER | |
| S08 | 6060----- | -- | ----- | - | - | 00=EXTRACT | |
| S09 | 0000----- | -- | ----- | - | 1 | 00=STEP 09 | END FORMULA #00 |
| F99 | TMMQFFFHC | LS | CCNNWSSS* | D | E | FORMULA 99 | FORMULA 99 |
| S01 | 3633---00 | 0- | 000000000 | 0 | - | 00=STEP 01 | |
| S02 | 0000----- | -- | ----- | - | 0 | 00=STEP 02 | END FORMULA #99 |
| F01 | TMMQFFFHC | LS | CCNNWSSS* | D | E | FORMULA 01 | LIGHT SOIL |
| S01 | 207016021 | 22 | | 0 | - | 13=BLE-SUDS | |
| | | .. | 010200600 | . | . | SOAP | |
| | | .. | 030620600 | . | . | CHLORINE BLEACH | |
| S02 | 202016021 | 31 | 000000000 | 0 | - | 05=RINSE | |
| S03 | 5002----- | -- | ----- | - | - | 00=EXTRACT | |
| S04 | 202014521 | 31 | 000000000 | 0 | - | 05=RINSE | |
| S05 | 5002----- | -- | ----- | - | - | 00=EXTRACT | |
| S06 | 204012023 | 30 | | 0 | - | 08=SOURSOFT | |
| | | .. | 040900600 | . | . | SOUR | |
| | | .. | 051000600 | . | . | SOFTENER | |
| S07 | 6060----- | -- | ----- | - | - | 00=EXTRACT | |
| S08 | 0000----- | -- | ----- | - | 1 | 00=STEP 08 | END FORMULA #01 |

PELLERIN MILNOR CORPORATION

W/E: 64042BTN MACHINE 7 VERSION 89002/5 DATE: 09/08/1989 PAGE: 02

FORMULA RANGE = 00, 99, 01-10 (Cont.)

CHEMICAL VALVES = 08

| | | | | | | | |
|-----|-----------|----|-----------|---|---|-----------------------|-----------------|
| F02 | TMMGFFFHC | LS | CONNWSSS* | D | E | FORMULA 02 HEAVY SOIL | |
| S01 | 207016021 | 21 | | 0 | - | 02=BREAK | |
| | | .. | 020100600 | . | . | ALKALI | |
| | | .. | 061600010 | . | . | NON IONIC DIL | |
| S02 | 207016021 | 21 | | 0 | - | 03=WASH | |
| | | .. | 010200600 | . | . | SOAP | |
| S03 | 207016021 | 22 | | 0 | - | 04=BLEACH | |
| | | .. | 030600600 | . | . | CHLORINE BLEACH | |
| S04 | 202016021 | 31 | 000000000 | 0 | - | 05=RINSE | |
| S05 | 5002----- | -- | ----- | - | - | 00=EXTRACT | |
| S06 | 202014521 | 31 | 000000000 | 0 | - | 05=RINSE | |
| S07 | 5002----- | -- | ----- | - | - | 00=EXTRACT | |
| S08 | 204012023 | 30 | | 0 | - | 08=SOURSOFT | |
| | | .. | 040900600 | . | . | SOUR | |
| | | .. | 051000600 | . | . | SOFTENER | |
| S09 | 6060----- | -- | ----- | - | - | 00=EXTRACT | |
| S10 | 0000----- | -- | ----- | - | 1 | 00=STEP 10 | END FORMULA #02 |

FELLERIN MILNOR CORPORATION

W/E: 64042BTN MACHINE 7 VERSION 89002/S DATE: 09/08/1989 PAGE: 01

CONFIGURE

| | | |
|------------------|------------------|--------------------|
| A=TEMP UNIT | J=COOLDOWN ERROR | S=AMPSAVER OPT |
| B=LANGUAGES | K=WATER OPT | T=TEMP PROBES |
| C=FXP MACHINE | L=REUSE OPT | U=NOT USED |
| D=EXTRACT SPEEDS | M=SPRAY OPT | V=NOT USED |
| E=STAPH GUARD | N=NOT USED | W=VARIABLE SPD OPT |
| F=ANTI-FLUG | O=NOT USED | X=MANUAL PASSWORD |
| G=BTH EXT E1-2 | P=BALANCING OPT | Y=NOT USED |
| H=STEAM ERROR | Q=BWF | Z=NOT USED |
| I=FILL ERROR | R=TWO SPEED WASH | |

ABCDEFGHIJKLMNOPQRSTUVWXYZ
0001030100000**10002**00**

OF CHEM VALVES : 08
MACHINE NAME : 64042BTN MACHINE 7
MILDATA : Q=NO

FELLERIN MILNOR CORPORATION

W/E: 64042BTN MACHINE 7 VERSION 89002/5 DATE: 09/08/1989 PAGE: 01

STEP NAMES

- 01 FLUSH
- 02 BREAK
- 03 WASH
- 04 BLEACH
- 05 RINSE
- 06 ANTCHLOR
- 07 SOUR
- 08 SOURSOFT
- 09 SOFTENER
- 10 MILDCIDE
- 11 FINISH
- 12 STARCH
- 13 BLE-SUDS
- 14 NAME ME
- 15 NAME ME

FELLERIN MILNOR CORPORATION

W/E: 64042BTN MACHINE 7 VERSION 89002/S DATE: 09/08/1989 PAGE: 01

CHEMICAL NAMES

| | | |
|--------------------|-----------------|-----------------|
| 01 ALKALI | 23 CHEM NAME 23 | 45 CHEM NAME 45 |
| 02 SOAP | 24 CHEM NAME 24 | 46 CHEM NAME 46 |
| 03 DETERGENT | 25 CHEM NAME 25 | 47 CHEM NAME 47 |
| 04 SOAP + ALKALI | 26 CHEM NAME 26 | 48 CHEM NAME 48 |
| 05 DETERG + ALKALI | 27 CHEM NAME 27 | 49 CHEM NAME 49 |
| 06 CHLORINE BLEACH | 28 CHEM NAME 28 | 50 CHEM NAME 50 |
| 07 OXYGEN BLEACH | 29 CHEM NAME 29 | 51 CHEM NAME 51 |
| 08 ANTICHLOR | 30 CHEM NAME 30 | 52 CHEM NAME 52 |
| 09 SOUR | 31 CHEM NAME 31 | 53 CHEM NAME 53 |
| 10 SOFTENER | 32 CHEM NAME 32 | 54 CHEM NAME 54 |
| 11 SOUR + SOFTENER | 33 CHEM NAME 33 | 55 CHEM NAME 55 |
| 12 STARCH | 34 CHEM NAME 34 | 56 CHEM NAME 56 |
| 13 ANTI-MILDEW | 35 CHEM NAME 35 | 57 CHEM NAME 57 |
| 14 ANTI-BACTERIA | 36 CHEM NAME 36 | 58 CHEM NAME 58 |
| 15 FINISHING CHEMS | 37 CHEM NAME 37 | 59 CHEM NAME 59 |
| 16 NON IONIC OIL | 38 CHEM NAME 38 | 60 CHEM NAME 60 |
| 17 CHEM NAME 17 | 39 CHEM NAME 39 | 61 CHEM NAME 61 |
| 18 CHEM NAME 18 | 40 CHEM NAME 40 | 62 CHEM NAME 62 |
| 19 CHEM NAME 19 | 41 CHEM NAME 41 | 63 CHEM NAME 63 |
| 20 CHEM NAME 20 | 42 CHEM NAME 42 | 64 CHEM NAME 64 |
| 21 CHEM NAME 21 | 43 CHEM NAME 43 | |
| 22 CHEM NAME 22 | 44 CHEM NAME 44 | |

Section
Operating



4

RUNNING A FORMULA IN AUTOMATIC WITH THE MARK II MICROPROCESSOR CONTROL

- Selecting The Formula In Non-tilting Washer-extractors
- Pre-selecting The Formula In Tilting Washer Extractors
- The Display During Automatic
- Restart In Automatic After Power Loss
- Using Formula 00 To Commission A Machine

Selecting The Formula In Non-tilting Washer-extractors

Master switch = ON

example:  ,  Display =

| |
|--------------------|
| RUN FORMULA |
| 00 OR OK POWER OFF |

Display =

| |
|-------------|
| RUN FORMULA |
| 08 SHEETS |

 If formula 08 exists, otherwise next higher available formula is displayed.

See special procedures for running Test Formula 00 in "USING FORMULA 00 TO COMMISSION A MACHINE" elsewhere herein.



Accepts displayed formula (sounds operator alarm if door is closed and latched).



Scrolls available formula numbers



Cancels operator alarm and starts the process.

The machine must be loaded with goods, the door closed and latched, and supply injector (if any) charged with chemicals, etc.

Pre-selecting The Formula In Tilting Washer-extractors

THE FOLLOWING DOES NOT APPLY TO MACHINES WITH MILNOR "WETCHUTE" OR "DRYEL" AUTOMATIC LOADING SYSTEMS.

Although the above formula selection and machine starting process may also be employed in tilting machines, the formula instead may be **pre-selected** (and accepted by pushing ) when the empty machine is at the non-tilted position with its loading door fully open. The drain valve(s) will then close as rearward tilting begins and the machine will fill to a special lower, fill-while-tilted liquor level with the commanded water (and temperature by thermo-modulation, but not by steaming). First bath chemicals not commanded to be injected after temperature is achieved will also be added. The commanded running liquor level will be satisfied after the door is closed and the machine returned to the non-tilted position.

NOTE: Close the door before returning machine to the non-tilted position, otherwise water may run out. Because it is difficult to close the door while tilted back, formula pre-selection is usually employed only on machines having an automatic (powered) door.

If the formula was not pre-selected before tilting, the machine must be returned to the non-tilted position before a formula may be selected.

The Display During Automatic

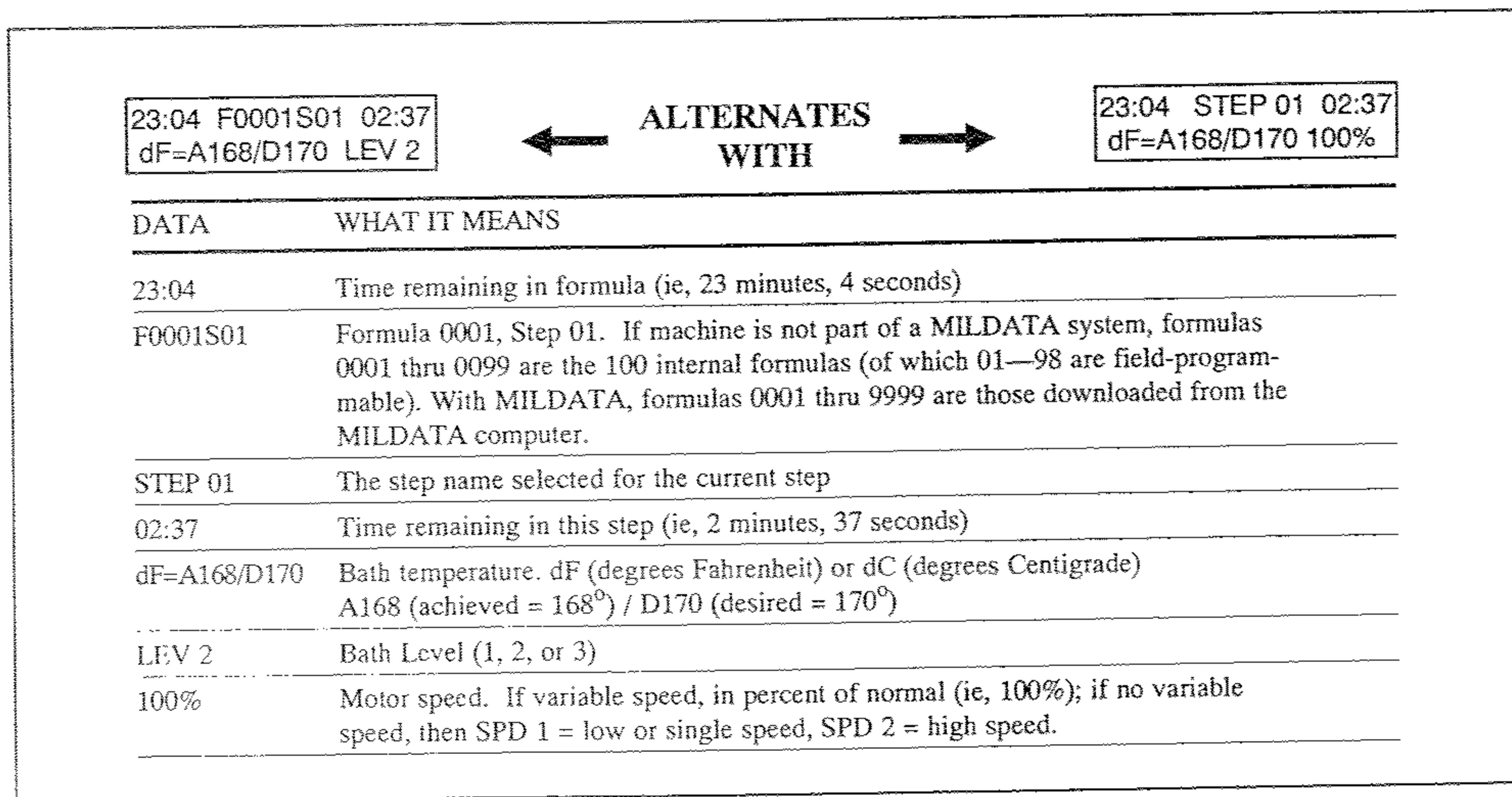

FIGURE 1 (MSOP0239AE)

Typical Alternating Displays in AUTOMATIC and after entering MANUAL MODE A



See **MANUAL MODE A** elsewhere herein for how to modify a running formula (extend or terminate a step, cancel the formula, etc.)

Restart In Automatic After Power Loss

This control remembers the operation it was in if power fails or the Master Switch is set to OFF while the machine is operating in Automatic. When power is restored, the following display will appear:

| |
|---------------------------|
| NEXT TO RESTART AT F S |
|---------------------------|

F and S are the interrupted Formula and Step numbers.

To resume the formula at the beginning of the last operation, press , then . If the outage occurred during a bath operation, level and temperature (if commanded) must again be satisfied, even if these were already satisfied before the power loss. If the outage occurs during a drain, the drain duration will be repeated and then followed by the next commanded step. If the outage occurs during an extract, the restart will be handled the same as an extract recycle.

To cancel this formula and return to "RUN FORMULA 00", press  (and enter the PASSWORD if requested—otherwise it is only possible to resume the formula).

Using Formula 00 To Commission A Machine

Formula 00 is similar to a medium soil formula. While it can be used to wash goods, it is intended to help commission a new machine. The formula is generic and may not take advantage of supplied options. It will run on any machine with two water valves to test the following:

- Filling to levels 2 and 3
- Hot, cold and split water selection (or cold, 2nd and cold+2nd, if a cold water machine). No temperatures are commanded in this formula.
- 60 second chemical injections from valves 01 through 05
- Wash reversing, intermediate extract and final extract
- Draining to sewer. The first drain is at wash speed and all others are at distribution speed.

Formula 00 is always available and cannot be copied, deleted, or permanently changed. A full description is included in the example printouts at the end of this manual.

Even if the password is enabled in CONFIGURE, it is not required to enter Manual Mode A or B, while running Formula 00.

Master switch = ON

Display =

| |
|-----------------------------------|
| RUN FORMULA 00 OR OK POWER OFF |
|-----------------------------------|

**ENTER
NEXT**

Accesses formula 00.

Display =

| |
|------------------------------|
| RUN FORMULA 00 FORMULA 00 |
|------------------------------|

START

Cancels operator alarm and starts the process.

or

**CANCEL
ESCAPE**

Cancels the step.

Display returns to

| |
|-----------------------------------|
| RUN FORMULA 00 OR OK POWER OFF |
|-----------------------------------|

VIEWING, PRINTING AND CLEARING ACCUMULATED FORMULA DATA (for Machines with Software Version 8900b and Later)

- Data Available
- How to Access Data Accumulation
- 0=DISPLAY DATA
- 1=PRINT
- 2=CLEAR

Data Available

The control stores data pertaining to loads processed that can be used for both accounting purposes and to gage efficiency of operation. This data is available for the last load processed. The control also accumulates totals per formula as well as for all formulas combined since the last time data was cleared. The data includes:

- **LOADS**—The number of loads processed.(if applicable)
- **FORMULA NUMBER**—(if applicable)
- **RUN TIME**—Total time taken to process a load, including drain, distribution, coast and any error time(see below).
- **WAIT TIME**—The time from when one formula ends to when the next one begins so long as the machine power remains ON. Wait time is always applied to the formula that follows it. If the machine remains on over-night, with the machine idle, this entire time is applied to the wait time for the first load processed the following day. Turn power off then back on before starting the first load to exclude idle time outside of normal operating hours.
- **ERROR TIME**—The time during which normal operation is suspended due to an error condition. This time is included in run time, see above.

How to Access Data Accumulation

With display at

RUN FORMULA
00 OR OK POWER OFF

Hold **MANUAL** (for 2 seconds). Display =

TURN OUTPUT ON
0

2 DEF Selects

DATA ACCUMULATION
2

ENTER NEXT

Displays the 3 available selections.

0 0=DISPLAY DATA
1=PRINT 2=CLEAR

CANCEL ESCAPE

Exits data accumulation. Display returns to

RUN FORMULA
00 OR OK POWER OFF

0=DISPLAY DATA

The accumulated data for the last load processed, the totals for each formula and the totals for all formulas may be viewed on the display.

When the display = **0** 0=DISPLAY DATA
1=PRINT 2=CLEAR

0, **ENTER** Selects
"0=DISPLAY DATA".

0 0=LAST LOAD
1=FORMS 2=TOTAL

CANCEL
ESCAPE Exits "DISPLAY DATA". Display returns to

0 0=DISPLAY DATA
1=PRINT 2=CLEAR

When the display = **0** 0=LAST LOAD
1=FORMS 2=TOTAL

0, **ENTER** displays the data for the last load processed.

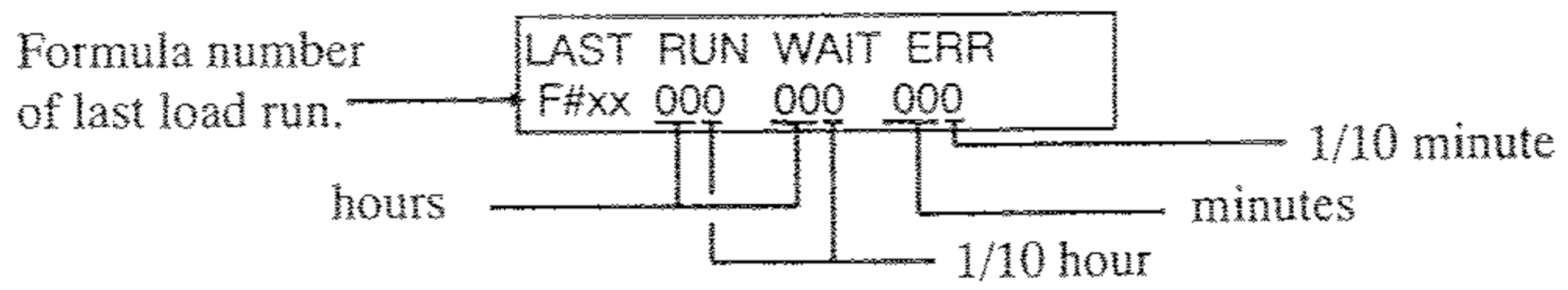

CANCEL
ESCAPE Exits "LAST LOAD". Display returns to

0 0=LAST LOAD
1=FORMS 2=TOTAL

When the display = **0** 0=LAST LOAD
1=FORMS 2=TOTAL

1, **ENTER** displays totals for the selected formula.

Use **↑** or **↓** to scroll through all the formulas or enter a formula number.

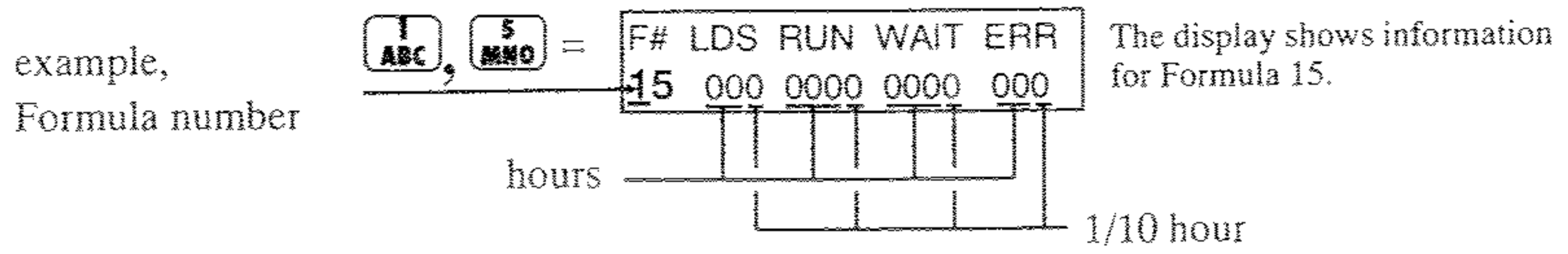

CANCEL
ESCAPE Exits "FORMS". Display returns to

1 0=LAST LOAD
1=FORMS 2=TOTAL

When the display = **0** 0=LAST LOAD
1=FORMS 2=TOTAL

2, **ENTER** displays totals for all formulas.

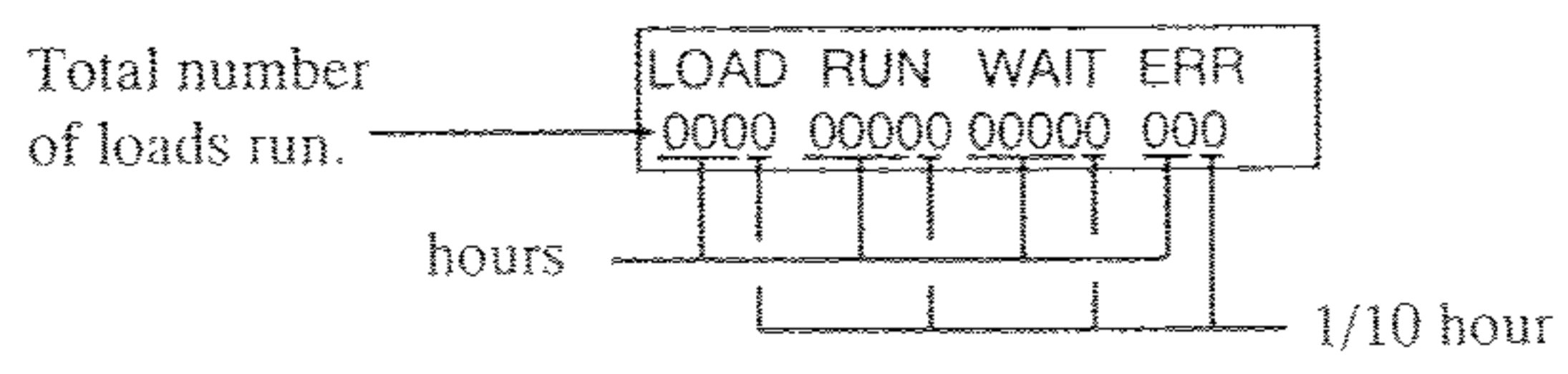

CANCEL
ESCAPE Exits "TOTAL". Display returns to

2 0=LAST LOAD
1=FORMS 2=TOTAL

1=PRINT

All accumulated data may be printed out on a serial printer. This printer must be connected by means of a Serial Link Cable to the External Serial Link Connector, see table of contents.

When the display = 0 0=DISPLAY DATA
1=PRINT 2=CLEAR 1
ABC, ENTER
NEXT Selects DATE: MM - DD - YYYY
00
1=PRINT.

CANCEL
ESCAPE Exits "PRINT". Display returns to 1 0=DISPLAY DATA
1=PRINT 2=CLEAR

The control provides for entering today's date at the top of the print-out.

When the display = DATE: MM - DD - YYYY
00 ENTER
NEXT, ENTER
NEXT, ENTER
NEXT bypasses the date.

example, 1
ABC, 2
DEF Enters month. Display = DATE: MM - DD - YYYY
12

ENTER
NEXT Accepts the month and advances cursor to DD.

0
!, 9
YZ- Enters day. Display = DATE: MM - DD - YYYY
12 - 09

ENTER
NEXT Accepts the day and advances cursor to YYYY.

1
ABC, 9
YZ-, 9
YZ-, 0
! Enters year. Display = DATE: MM - DD - YYYY
12 - 09 - 1990

ENTER
NEXT Accepts the year and begins printing.

Display = PRINTING...
** PLEASE WAIT **

When printing is finished, display returns to 1 0=DISPLAY DATA
1=PRINT 2=CLEAR

2=CLEAR

Accumulated data may be cleared at any time the machine is idle. All data will be cleared simultaneously.

When the display = 0 0=DISPLAY DATA
1=PRINT 2=CLEAR 2
DEF, ENTER
NEXT Selects NEXT TO CLEAR DATA
CANCEL=ESCAPE
"2=CLEAR".

ENTER
NEXT Clears all accumulated data from memory. Display returns to 2 0=DISPLAY DATA
1=PRINT 2=CLEAR

CANCEL
ESCAPE Exits "CLEAR" without clearing the accumulator. Display returns to 2 0=DISPLAY DATA
1=PRINT 2=CLEAR

FELLERIN MILNOR CORPORATION

W/E: 64042BTN MACHINE 7 VERSION 8900B/S DATE: 03/19/1990 PAGE: 01

DATA ACCUMULATION

0 = LAST FORMULA RUN

| FORMULA # | RUN TIME HHT | WAIT TIME HHT | ERROR TIME MNT |
|-----------|--------------|---------------|----------------|
| 10 | 000 | 000 | 000 |

1 = DATA PER FORMULA

| FORMULA # | # OF LOADS # | RUN TIME HHHT | WAIT TIME HHHT | ERROR TIME HHT |
|-----------|--------------|---------------|----------------|----------------|
| 00 | 001 | 0000 | 0000 | 000 |
| 01 | 003 | 0000 | 0000 | 000 |
| 05 | 002 | 0000 | 0000 | 000 |
| 10 | 004 | 0000 | 0000 | 000 |

2 = TOTAL ACCUMULATION DATA

| TOTAL | # OF LOADS # | RUN TIME HHHHT | WAIT TIME HHHHT | ERROR TIME HHT |
|-------|--------------|----------------|-----------------|----------------|
| | 0010 | 00000 | 00000 | 000 |

NOTES:

- # = Number
- HHT = Hours-Hours-Tenth of hour
- HHHT = Hours-Hours-Hours-Tenth of hour
- HHHHT = Hours-Hours-Hours-Hours-Tenth of hour
- MNT = Minutes-Minutes-Tenth of minute
- x = Data has reached maximum stored value.

MANUAL FORMULA MODIFICATIONS WITH THE MARK II MICROPROCESSOR CONTROL

- How The Manual Password Works
- Manual Mode A-modifying a Running Formula without Pressing [MANUAL]
- Manual Mode B-modifying a Running Formula after Pressing [MANUAL]
- Using Formula 99 to Develop/Test a New Formula



How the Manual Password Works

If MANUAL PASSWORD=YES in Program Menu, Mode 5=CONFIGURE, decision X, the correct four-digit PASSWORD must be entered before intervention under MANUAL MODE A or B is permitted.

FOR MANUAL MODE A (WITHOUT PRESSING)



Once a valid PASSWORD is entered, any number of the functions available in this mode can be performed if each keystroke is no more than 10 seconds after the last. After 10 seconds the PASSWORD must be reentered.

Whenever the PASSWORD is required, the control will prompt for it. For example, to raise bath temperature:

 +  If password protection is configured,

Display =  PASSWORD is a four digit number, previously configured.

[a, b, c, d] (means type the PASSWORD) **Must be entered within 10 seconds.**

 +  Raises bath temperature (If entered within 10 seconds after valid password entered).

As in the above example, any manual functions that require key(s) to be held depressed also require the key stroke(s) to be reentered after entering the PASSWORD.

If an invalid PASSWORD is entered or after 10 seconds,

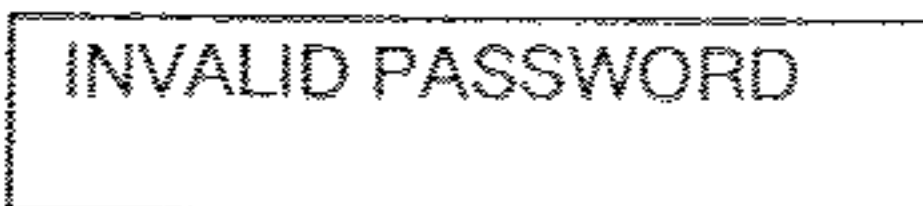
the display momentarily =  Then it returns to the AUTOMATIC RUN displays.

FOR MANUAL MODE B (AFTER PRESSING)

Once the PASSWORD has been used to enter MANUAL MODE B, it is no longer required to start or stop any functions, or to escape.

Manual Mode A - Modifying a Running Formula without Pressing [MANUAL]

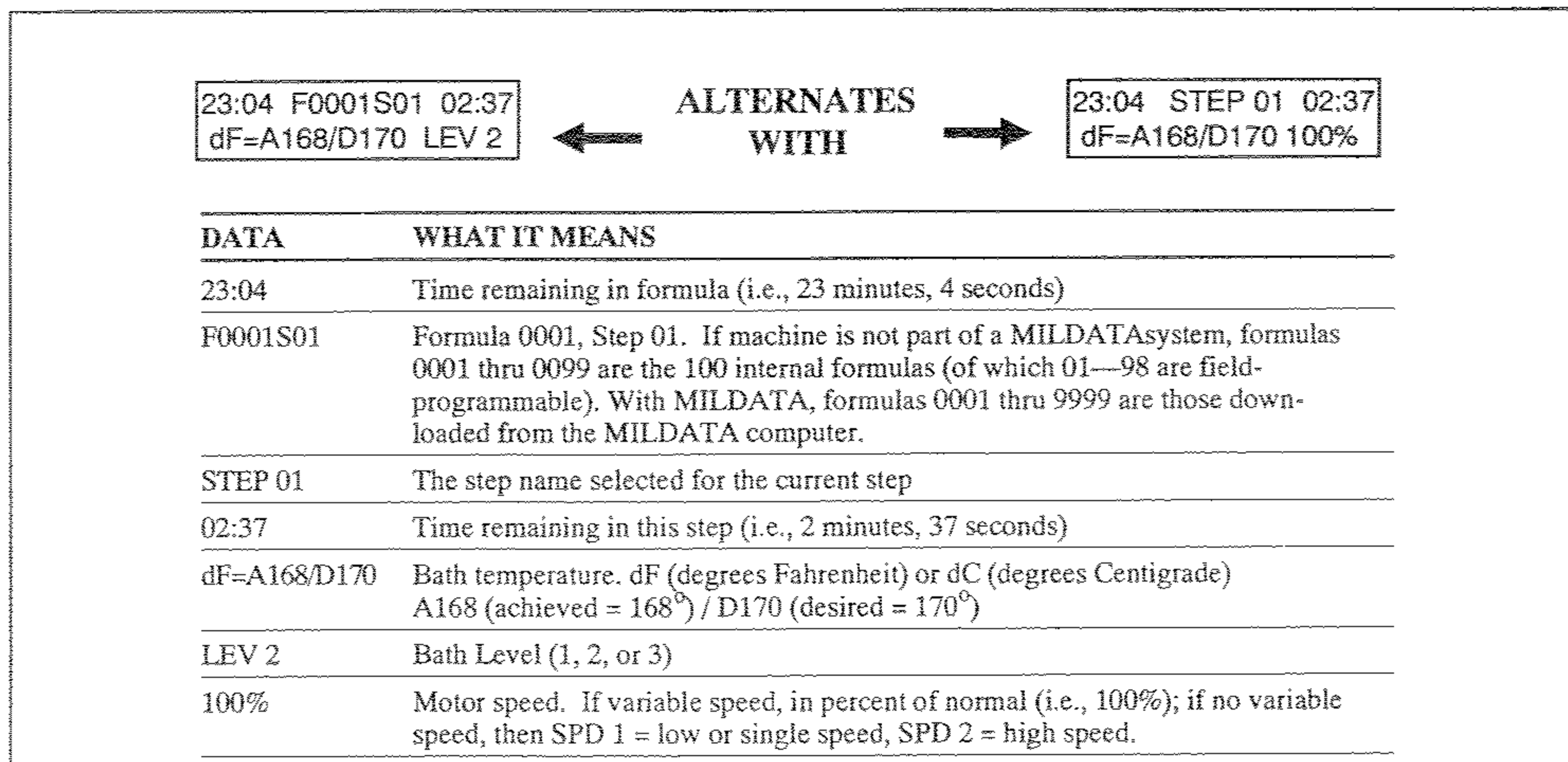

FIGURE 1 (MSOP0236AE)
Typical Alternating Displays In Automatic and After Entering MANUAL MODE A

TIMER STOP

Stops the formula timer. All functions in progress continue.

CANCEL ESCAPE resumes timing.

EXTEND HELP

Extends bath or extract in progress one minute. (Repeat for each additional minute)

EXTEND HELP

Extends drain in progress ten seconds. (Repeat for each additional ten seconds.)

CANCEL ESCAPE

Terminates a bath, a drain proceeding a bath, or an extract in progress; and proceeds to the next operation. (Will not shorten a drain preceding an extract.)

STOP, CANCEL ESCAPE

Cancels the formula in progress.

LEVEL + ↑

Raises the commanded level in this bath. Injects water to the newly displayed level using the water valves/thermo-modulation commanded for this bath in the formula.



Lowers the displayed level in this bath. Will not actually lower the commanded level before any extract, nor any commanded level that has already been achieved.



Raises/lowers bath temperature. Only if water temp thermostatically controlled; will not lower a temperature already achieved.

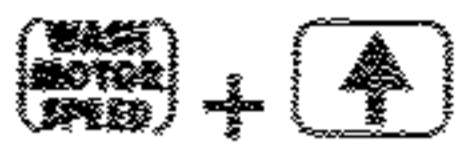

Increases basket speed of bath or extract in progress (only if machine is so equipped). (The display skews approximately 2% per second.)



Decreases basket speed of bath or extract in progress (only if machine is so equipped). (The display skews approximately 2% per second.)

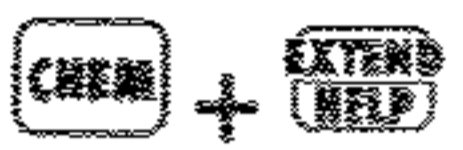

Injects chemical at any time during a bath. Injection continues for one second after keys are released. Drain(s) must be closed, but level and/or temperature not considered.

(x = chem number from 1 to 8)

OR



(For chem 9-15, y = 1-7)

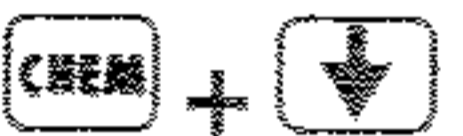

Flushes the supply injector manifold.

Manual Mode B - Modifying A Running Formula after Pressing [MANUAL](cannot be entered during drain or extract)

Once in Manual Mode B, Password not required to start or stop a function, or to escape.



Enters Manual Mode B. All water, steam, and chemical valves close; the timer stops, and the display alternates between the two shown in Figure 2, next page. The drain valve and wash motor status remain unchanged. See table on next page for available actions.

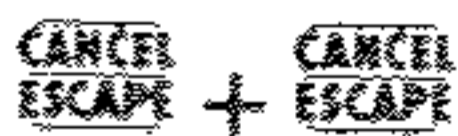

Exits Manual Mode B. The RUN display returns and interrupted automatic formula is resumed except with no further chemical injections in the interrupted bath. If any outputs are on, the first turns them off, and the second displays "ESCAPE? SELECT 00".

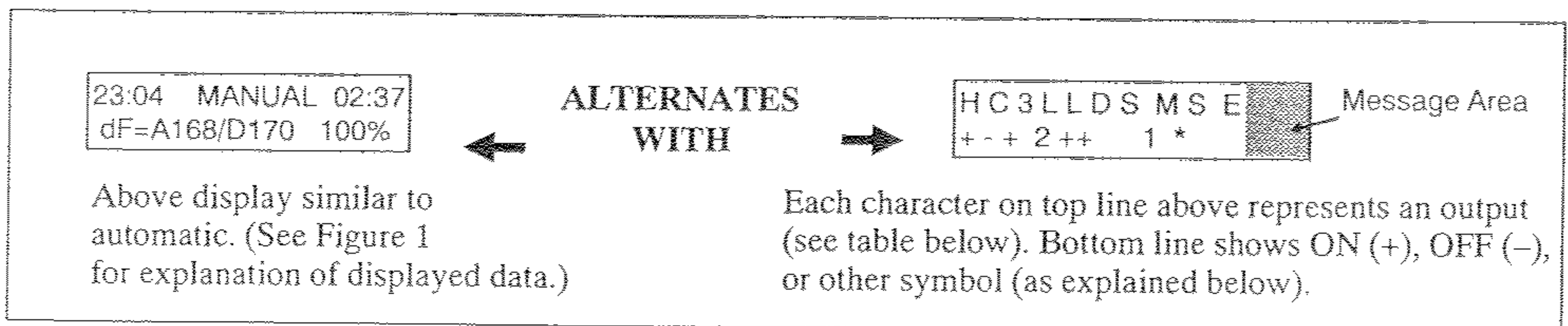



FIGURE 2(MSOP0236AE)
Typical Alternating Displays After "MANUAL" Key Pressed

Functions Available After "MANUAL" Key Pressed

| Display Code | Output | Press to turn ON | Press to turn OFF | Comments |
|---|----------------|---|-------------------|--|
| § H | Hot water | | | Water valves close automatically at Level 3. Hold keys depressed for more water. |
| C | Cold water | | | Water valves close automatically at Level 3. Hold keys depressed for more water. |
| § 3 | Third water | | | Water valves close automatically at Level 3. Hold keys depressed for more water. |
| L L | Liquor Level | <i>(information only, use water keys to change)</i> | | 1, 2, or 3 shows level made; * = below lev 1 |
| D | Drain to Sewer | | | S or R and SEWER/REUSE DRAIN message indicates draining to sewer or to reuse. A "+" indicates drain(s) closed. |
| § | Drain to use | | | Opening either drain disables the other drain valve and all water, steam and chemical valves. |
| § S | Steam | | | Steam cannot be enabled until level 1 satisfied, and once bath temperature reaches 207°F (97°C) |
| M | Wash Motor | | | Starts with delay. Powers off instantly, brake not applied. |
| S | Wash Speed | | | 1 or 2 indicates speed; "*" means stopped or var. speed. Pressing key displays speed. |
| <i>(alone displays speed; with arrow changes speed)</i> | | | | |
| E | Extract | | or | Display prompts "EXTRACT 0=L 1=H". Extracts for 5 minutes or until cancelled. |
| | or | | or | Must reach Level 2 before extract allowed. Drains to sewer or reuse as commanded. |
| | Chem 1 - 8 | | not applicable | Chemical valves close instantly when keys are released. |
| <i>(X = chemical number from 1 to 8)</i> | | | | |
| | Chem 9 - 15 | | not applicable | Chemical valves close instantly when keys are released. |
| <i>(For Chem 9 thru 15, Y = 1 thru 7)</i> | | | | |
| | | | not applicable | Flush valve closes when keys are released. |
| | Cooldown | | | COOLDOWN message appears. Steam and all other water valves disabled. Cooldown valve opens and stays open until turned off. |

§ Machine must be equipped with this device.

Using Formula 99 to Develop/Test a New Formula

Formula 99 is a 63.75 minute bath with no water or any other functions and with the cylinder stopped. To develop/test a process without programming a new formula, run Formula 99 and use the procedures described in "MANUAL MODE B - MODIFYING A RUNNING FORMULA AFTER PRESSING ".

Formula 99 is always available and cannot be copied, deleted, or permanently changed. For a detailed description, see the example printouts at the end of this manual.

Even if the password is enabled in CONFIGURE, it is not required to enter Manual Mode A or B while running Formula 99.

HOW TO SET WATER LEVELS IN WASHER EXTRACTORS WITH MARK II MICROPROCESSOR CONTROLS

- Factory settings
- Setting The Water Levels
- Adjusting The Float Actuated Level Control
- Adjusting The Pressure Actuated Level Control

These washer extractors have three adjustable water levels. (Additionally, open pocket machines have a pressure switch to allow the door to be opened if the level is low enough and tilt-to-load models have a lower water fill level when the machine is tilted back. **Both these levels must be left at the factory setting** and are therefore, not described in this section.) The adjustable levels are:

| LEVEL | USE FOR |
|------------------|------------------------------|
| Level 3 (High) | Rinse, distribution, wetdown |
| Level 2 (Low) | Wash, distribution, wetdown |
| Level 1 (Starch) | Starching |

There is no separate Cooldown level. Cooldown occurs at the commanded level in the bath in which Cooldown is commenced.

Factory Settings

Factory settings shown below specify the depth of the bath **inside** the cylinder. The levels in open pocket cylinders (which slope down to the rear) are **at the rear** (deepest part) of the cylinder. The levels in divided cylinder machines (which hang level, front to back) are **at the sight glass**.

The goods in a loaded, rotating cylinder both absorb water and occupy space. Thus, depending on load size, type of goods, etc., it is likely that either more or less water will be needed to achieve any level compared to when filling an empty, stationary cylinder.

Factory Set Water Levels (Figures are in inches and () millimeters)

DIVIDED CYLINDER MODELS (Measured at Sight Glass)

| Model | L1* | L2* | L3 |
|-------|---------|---------|----------|
| 42031 | 4 (102) | 7 (178) | 12 (305) |
| 42044 | 4 (102) | 7 (178) | 12 (305) |
| 60036 | 4 (102) | 9 (229) | 14 (356) |
| 60044 | 4 (102) | 9 (229) | 14 (330) |
| 72044 | 4 (102) | 9 (229) | 14 (356) |
| 72044 | 4 (102) | 9 (229) | 14 (356) |

* See next page.

OPEN POCKET MODELS (Measured at Rear of Cylinder)

| Model | L1* | L2* | L3 |
|-------------|-----------|-----------|------------|
| 36021/36026 | 3 (76) | 7 (178) | 12 (305) |
| 42026 | 8 (203) | 10 (254) | 13 (330) |
| 48032 | 9 (229) | 11 (279) | 14 (356) |
| 48036 | 9 (229) | 11 (279) | 14 (356) |
| 52038 | 7.5 (191) | 9.5 (241) | 14.5 (368) |
| 64042 | 10 (254) | 12 (305) | 14 (356) |
| 72044 | 8 (203) | 10 (254) | 15 (381) |

*** SETTING LOWER LEVELS THAN SHOWN CAN CAUSE MALFUNCTIONS**

The heights shown in the "FACTORY SET WATER LEVELS" table for Levels 1 and 2 are minimums. Never set these levels lower than stated in the table.

Setting The Water Levels

It is not possible to determine a water level by observing the level while the machine is rotating OR with a load of goods in the cylinder. Always measure the level with the cylinder at rest and without goods.

Setting Water Levels in Open Pocket Machines

1. With the cylinder empty, measure from the bottom inside of the cylinder and place clearly visible marks on the rear wall at each of the three desired levels.
2. Close the door. Run Formula 99. (The cylinder will be stationary and without water). Enter Manual Mode B which stops the timer. (See "MANUAL FORMULA MODIFICATIONS" elsewhere herein.) Now press **COLD** to manually add cold water and press **CANCEL** to stop the incoming water as it approaches the desired level. Now set the appropriate (L1, L2 or L3) level control so the proper level number (1, 2, or 3) for the just-established level just appears on the display (see FIGURE 1).

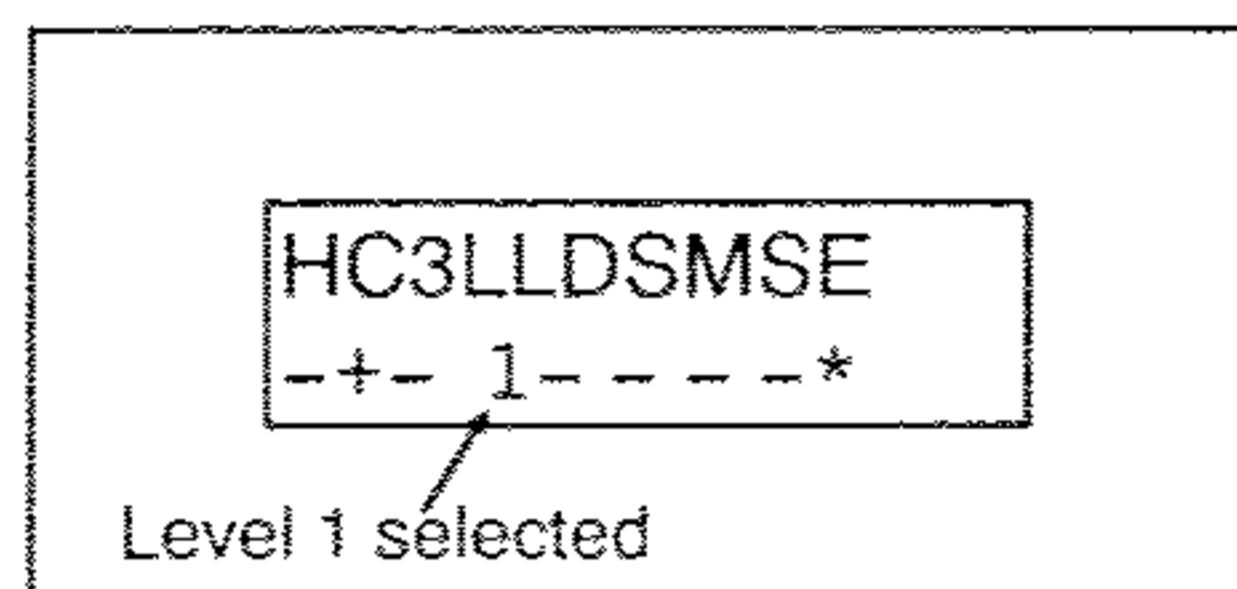

FIGURE 1 (MSSM0238AE)
Display in Manual Mode B

Repeat this procedure for each of the 3 levels.

Setting Water Levels in Divided Cylinder Machines

Except that the water levels are easily seen on the calibrated sight glass, the procedure is otherwise exactly the same as in open-pocket machines.

Type of Water Level Controls Used

| WATER LEVEL | WATER LEVEL CONTROL DEVICES USED ON | | |
|--------------|-------------------------------------|-----------------------|-----------------|
| | TILT-TO-LOAD | OPEN POCKET, NON-TILT | STAPH GUARD |
| Level 1 | Pressure Switch | Pressure Switch | Pressure Switch |
| Level 2 | Float Actuated | Float Actuated | Pressure Switch |
| Level 3 | Float Actuated | Float Actuated | Pressure Switch |
| OK Door Open | Pressure Switch | Pressure Switch | not applicable |
| Tilt Level | Pressure Switch | not applicable | not applicable |

All lower level switches must make; i.e., for L2, L1 and L2 must make. For L3, L1 + L2 + L3 must make.

Adjusting the Float Actuated Level Control

On machines that use a level float to control levels 2 (Low) and 3 (High), these levels are changed by moving the upper or lower float rod clips as explained in Figure 2 at right

The top of the float rod is shortened so the upper clip cannot be raised—and the resulting level 2 lowered—below the height prescribed in the **FACTORY SET LEVELS** chart herein. At lower levels the goods will not be fully wetted, resulting in poor washing and unbalanced extractions.

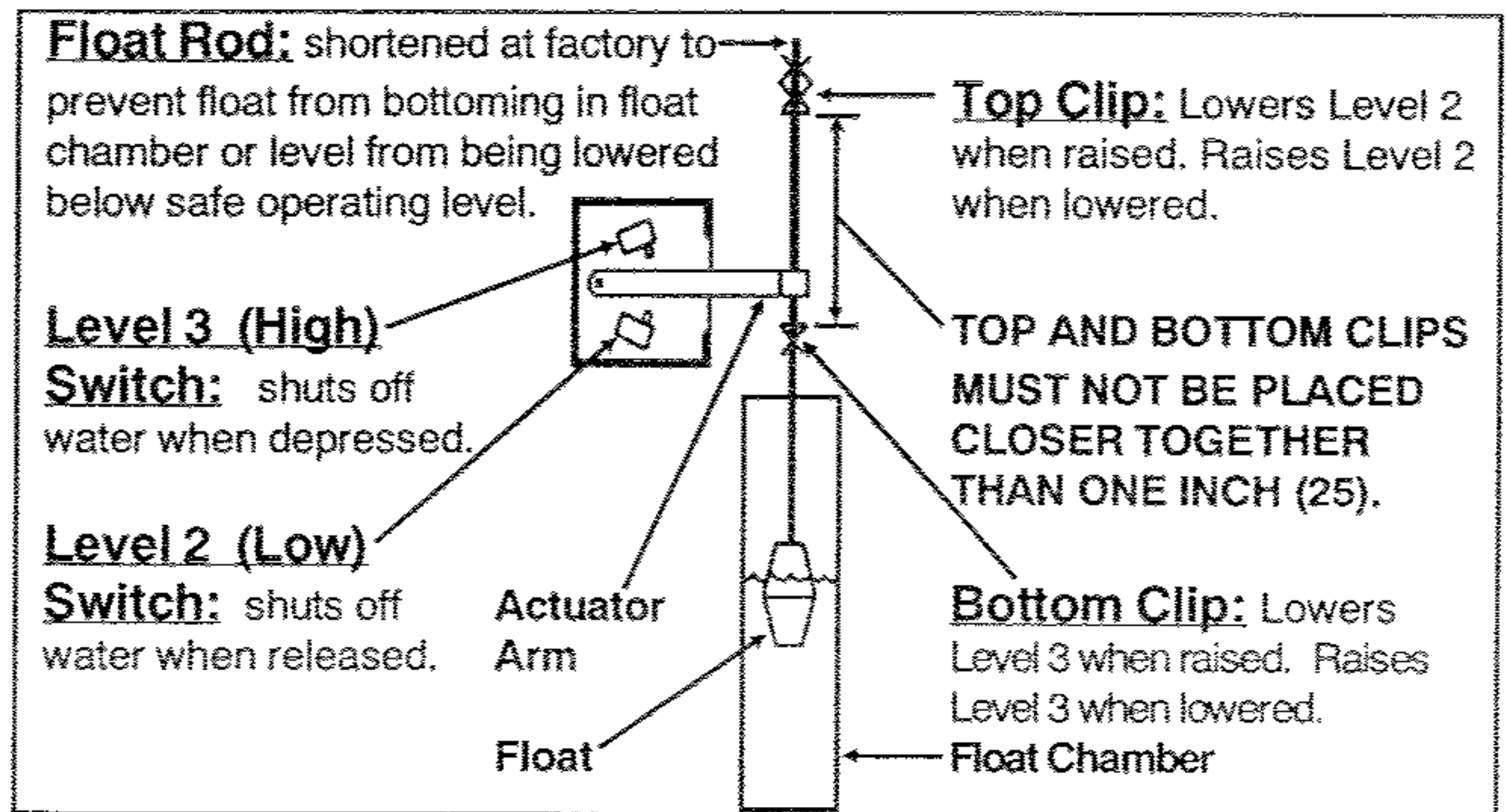

FIGURE 2(MSSM0238AE)
Float Actuated Level Control

PLACING CLIPS TOO CLOSE TOGETHER WILL CAUSE MALFUNCTIONS

Never place the upper and lower clips closer together than one inch (25), as shown, as this will bind the actuator arm and cause a malfunction.

Adjusting the Pressure Actuated Level Control

How the Pressure Switch Works—Much like the pressure rises inside an inverted glass as it is pressed into water, the pressure rises inside a chamber connected to the washer shell as the water level rises in the shell. The pressure switch, located in the washer's electric box and connected to the air chamber by a plastic tube, detects this change in pressure.

GUARD AGAINST OVERFLOWS-INSPECT AIR TUBES

A crimp, cut or loose connection in the plastic air tube will prevent the pressure switch from functioning. This will cause the machine to overflow.

The function of any pressure switch(es) used in your machine may be identified by the item number as follows:

SPLL1 = Level 1
SPLLL = Level 2
SPLL3 = Level 3
SPLDT = OK Open Door
SPTLT = Tilt Level

The part numbers can be found on the components list the machine's electrical schematic.

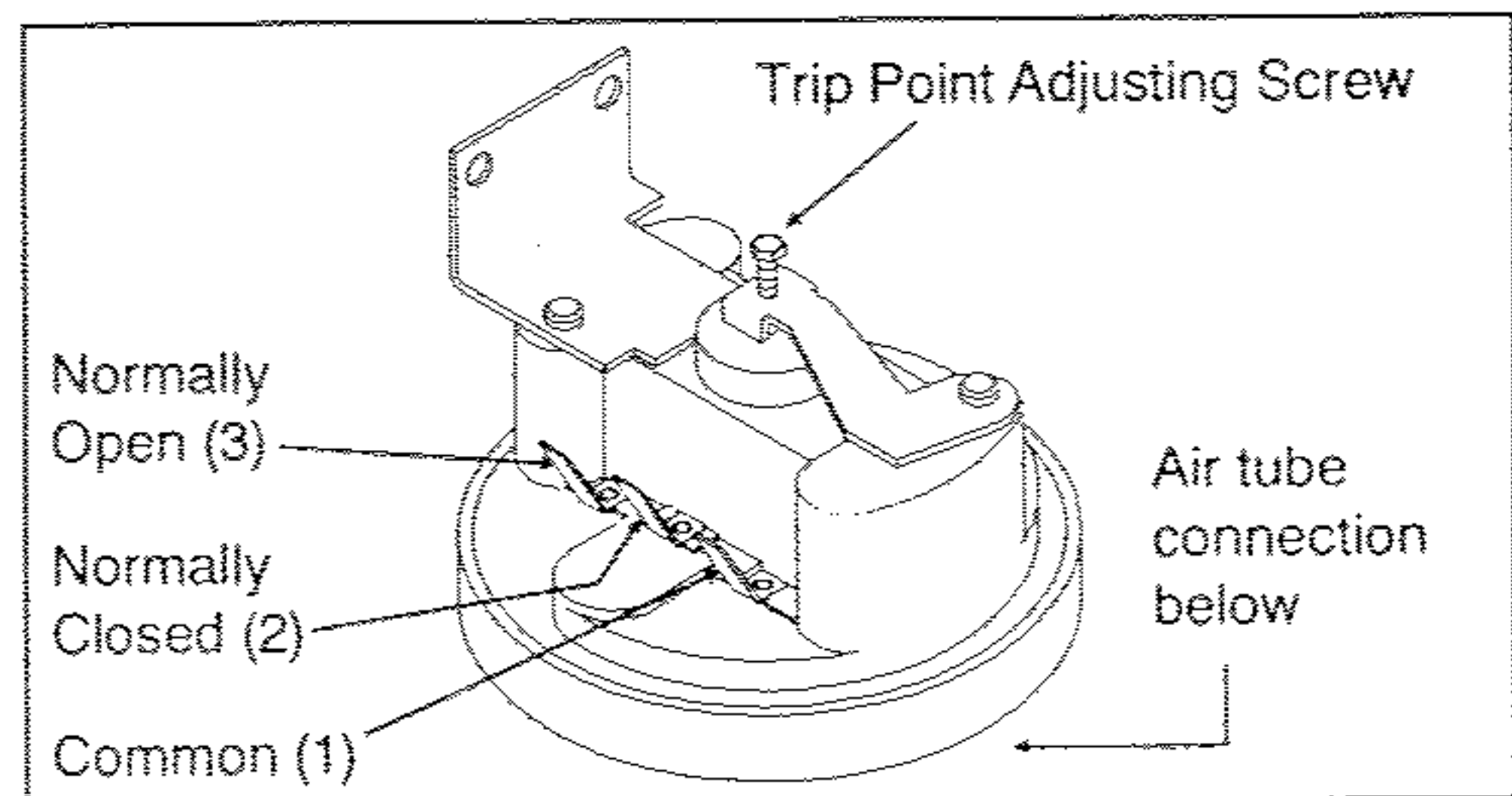

FIGURE 3 (MSSM0240AE)
Pressure Switch

Pressure switches have one Trip Point Adjusting Screw on each switch as shown in FIGURE 3. The switch manufacturer calibrates these switches to achieve the specified level. When the switch is installed, the washer is tested for proper water levels and when these are verified, the trip point adjusting screw is painted with wax, to hold its adjustment.

How to Adjust Pressure Switches—It is normally unnecessary to adjust the levels. However, if this is desired, always measure the level with the cylinder at rest and without goods. It is not possible to determine a water level by observing the level while the machine is rotating or with a load of goods in the cylinder.

1. Fill the washer to the level to be adjusted as described in "SETTING THE WATER LEVELS" above.

⚠ WARNING ⚠

The adjusting screw may become electrically energized when power is on. Use only an insulated screwdriver to make adjustments.

2. With an insulated screwdriver, turn the center trip point adjusting screw one half turn in the desired direction. Turn clockwise to raise the level or counter-clockwise to lower the level.
3. Check level.
4. Repeat step 2 as required, to achieve the desired level.

Section
Troubleshooting

5

VIEWING INPUTS/OUTPUTS AND ACTUATING OUTPUTS ON THE MARK II MICROPROCESSOR CONTROL

MANUAL PASSWORD IS NOT REQUIRED FOR ANY OF THESE FUNCTIONS.

- Viewing Inputs
- Viewing Outputs
- How To Perform Extract System Test
- How To Enter Bare Manual
- Controlling Individual Outputs For Testing
- Viewing Individual Inputs While In "bare Manual"

Viewing Inputs

hold **7**
STU

Displays 1st
16 inputs (0: A-P) .

(0) ABCDEFGHIJKLMNOP
- + - + - + - + - + - + - + - +

"+" =input energized
"-" =input not energized

hold **7**
STU + **1**
ABC

Displays 2nd 16 inputs (1: A-P)

Table of Standard INPUTS for Washer Extractors

| Display Code | hold 7 STU for 1st 16 | | hold 7 STU + 1 ABC for 2nd 16 | |
|--------------|--|---------------|---|---------------|
| | Input Name | Connector/Pin | Input Name | Connector/Pin |
| A | On Line PC | 1MTA38-8 | Rear Is Up | 1MTA3-10 |
| B | Program Key | 1MTA38-3 | Door Is Open | 1MTA3-9 |
| C | Signal Cancel | 1MTA38-2 | High Water Level | 1MTA3-8 |
| D | Coarse Balance | 1MTA38-5 | Low Water Level | 1MTA3-7 |
| E | Excursion | 1MTA38-6 | Starch Water Level | 1MTA3-4 |
| F | Three Wire | 1MTA38-7 | Check Drain Clutch | 1MTA3-3 |
| G | not used | | Chemical Save | 1MTA3-2 |
| H | not used | | Speed Switch | 1MTA3-1 |
| I | Clean Control | 1MTA39-1 | Amps Are OK | 1MTA4-10 |
| J | not used | | Front Not Down | 1MTA4-9 |
| K | not used | | Tilt Level | 1MTA4-8 |
| L | not used | | Brake Released | 1MTA4-7 |
| M | not used | | E2 Overload | 1MTA4-4 |
| N | not used | | E1 Overload | 1MTA4-3 |
| O | not used | | Drain Overload | 1MTA4-2 |
| P | not used | | Wash Overload | 1MTA4-1 |

Viewing Outputs

hold **8** **VWX** Displays 1st 16 outputs (0: a-p) (0) a c d e f g h i j k l m n o p
- + - + - + - + - + - + - + “+”=input made
“—”=input not made.

hold **8** **VWX** + **1** **ABC** Displays 2nd 16 outputs (1: a-p)

hold **8** **VWX** + **2** **DEF** Displays 3rd 16 outputs (2: a-p)

Table of Standard OUTPUTS for Washer Extractors

| Display Code | hold 8 VWX for 1st 16 outputs Model | Output Name | hold 8 VWX + 1 ABC for 2nd 16 outputs Model | Output Name | hold 8 VWX + 2 DEF for 3rd 16 outputs Model | Output Name |
|--------------|--|-----------------------------------|--|---------------------------------|--|----------------------------------|
| a | all | Drain Motor | all | Brake (+=released) | all | *Chemical 14 |
| b | all | *Cooldown | all | H ₂ O Valve #1 | all | *Chemical 9 |
| c | all | Two Speed Wash (Low Speed) | all | *H ₂ O Valve #2 | all | *Chemical 13 |
| d | all | *Chemical 4 | all | *H ₂ O Valve #3 | all | *Flush |
| e | all | *Chemical 1 | all | Drain to Sewer (+ = closed) | all | *Chemical 15 |
| f | all | *Chemical 3 | all | *Drain to Reuse (— = closed) | all | *Chemical 11 |
| g | all | *Chemical 2 | all | Wash Clutch | all | Chemical Save (+ = injecting) |
| h | all | *Chemical 5 | HYDRO- CUSHION | Push Down | all | not used |
| | | | BWP, FxP | Top Fill | | |
| i | all | High Extract (E2) | | not used | | *Chemical 10 |
| j | Balancing | Balance Enabled | | not used | all | *Amp Saver |
| | Divcyl | Spray Down | | | | |
| | Staph- Guard | Transfer Control to Clean Side | | | | |
| k | all | Extract Oper (E1) | | not used | all | *Chemical 6 |
| l | all | Clockwise Wash | | not used | all | *Chemical 7 |
| m | all | Counter-Clockwise Wash | | not used | all | *Chemical 8 |
| n | all | **Steam | | not used | | *Chemical 12 |
| o | all | Signal | | not used | | not used |
| p | all | Three-Wire | | not used | | not used |

* Must have optional hardware

** Optional on 4226 OHP, OTL, OTN; standard on all others

How To Perform An Extraction System Test

AVOID DAMAGE

NEVER RUN THIS TEST WITH GOODS IN THE BASKET because the machine will try to accelerate into drain speed from a dead stop, which may cause the drain speed motor to stall because it may not have sufficient torque. However, it is permissible to securely attach (with heavy duct tape or other reliable means) a well padded and well distributed (no "point contacts") off-center load inside the basket to test the extraction (and water balancing systems, if any) with an imbalance. This test disables the Excursion switch on Hydrocushion and foundationless machines and the Coarse Balance switch on self balancing machines. This can have the following detrimental consequences which the tester must guard against:

1. On hydrocushion and foundationless machines, the shell can bang around inside the house. If this occurs stop the test immediately.
2. The Vibration Safety switch on rigid mount machines is the only device that protects it during the extract test. (Self balancing rigid mount machines will not coast during the test.) If a severe out of balance fails to trip the Vibration Safety switch, stop the test immediately.
3. Machines with 2 extract speeds can enter high extract even if the load didn't balance in the first stage. This results in the conditions described in #1 and #2 above.

To test Excursion switch operation on Hydrocushion and foudationless machines, or the Coarse Balance switch operation on self balancing machines, it is necessary to run a programmed formula.

With master switch on and key switch at "RUN",

display =

RUN FORMULA
00 OR OK POWER OFF

0
.:

Moves cursor to second "0".

Display =

RUN FORMULA
00 OR OK POWER OFF

EXTRACT

Basket accelerates to drain speed, then to extract with balance system enabled (if any). Extract continues until **STOP** pressed.

EXTRACT TEST

STOP

Ends extract test. Braking continues for at least 30 seconds or until speed switch contacts close, whereupon clutch reengages with all motors stopped.

BRAKING

How To Enter Bare Manual

With display at RUN FORMULA
00 OR OK POWER OFF

Hold MANUAL for 2 seconds). Display = TURN OUTPUT ON
0

1
ABC Selects LOOK AT INPUTS
1

or

2
DEF Selects DATA ACCUMULATION
2

↑ or ↓ Scrolls the available choices

ENTER
NEXT Enters mode 0, 1 or 2 selected in previous step

Testing Individual Outputs In Bare Manual

(If "TURN OUTPUT ON/0" was selected)

PRESS START Display = ABORT MANUAL OPER
00

Select any OUTPUT by entering its 2-digit number (keypad entry) in the Table of "Bare Manual" OUTPUTS, on the following page.

0
0 1
ABC Selects Output #1
Clockwise Wash Rotation. Display = CLOCKWISE
01

ENTER
NEXT Turns output ON. Display = CLOCKWISE
01 ON

CANCEL
ESCAPE Turns output OFF. Display = CLOCKWISE
01 OFF

The output currently ON must be turned OFF before another can be turned ON.

0
0 2
DEF Selects Output #2. Select any output by entering it's number.

0
0 0
0 = ABORT MANUAL OPER
00

ENTER
NEXT Exits testing outputs in "BARE MANUAL." Display = RUN FORMULA
00

Table of "Bare Manual" OUTPUTS

| Keypad Entry | Output Name | Machine Model | Consequences of Actuating Outputs |
|--|------------------------|-------------------------------|---|
| 00 | ABORT MANUAL OPER. | all | Return to "RUN FORMULA" |
| 01 | CLOCKWISE | all | Turn basket clockwise at wash speed. |
| 02 | COUNTER-CLOCKWISE | all | Turn basket counter-clockwise at wash speed. |
| 03 | DRAIN SPEED | all | Turns basket at drain speed (clockwise). |
| 04 | CLUTCH | all | Clutch normally engaged when Master Switch ON. Remains engaged when this output turned ON. When output turned OFF, clutch disengages. |
| <i>When "BARE MANUAL" is entered, Pushdown (28) and Clutch (04) are actuated. When either output is actuated and turned OFF to exit, clutch remains disengaged, allowing wash or drain motor operation without damage.</i> | | | |
| 05, 06, 07 | WATER VALVES 1, 2, 3 | all | Opens valve. |
| 08 | SEWER DRAIN | all | Output ON closes drain. |
| 09* | REUSE DRAIN | all | Output ON opens drain. |
| 10 | BRAKE | all | Output ON releases brake. |
| 11 thru 25* | CHEMICALS 1 through 15 | all | Operates chemical 01-15 inject device |
| 26* | STEAM | all** | Opens steam valve. |
| 27* | COOLDOWN | all | Opens cooldown valve. |
| 28 | PUSHDOWN | all HYDRO CUSHION | Pushdown engaged when Master Switch ON. When this output is ON, clutch remains engaged; clutch disengages when this output is turned OFF. |
| <i>Clutch air supply routed through pushdown valve so when pushdown valve is OFF, air supply to clutch is OFF.</i> | | | |
| 28 | BOTTOM FILL | BWP and FxP only | Closes diverter valve to door hose and opens valve to bottom fill hose. |
| 29 | SIGNAL | all | Sounds operator alarm. |
| 30 | AUX BALANCE | BWP/BHP/ BTL/BTN | Enables balancing circuit |
| 30 | SPRAY DOWN | 60" & 72" WP2 (RAPID LOAD) | Opens spray down valve. |
| 30 | TRANSFER CLEAN/SOIL | SP2/SP3 | Transfers control to clean side. |
| 31 | MANIFOLD FLUSH | all | Operates manifold flush valve for supply injector. |

* Must have optional hardware.

** Optional on 4226 QHP, QTL, QTN. Standard on all others.

The extract motor can not be actuated in BARE MANUAL; see How to Perform Extract System Tests, elsewhere herein.

Viewing Individual Inputs In Bare Manual

(If "LOOK AT INPUTS/1" was selected)

ENTER
NEXT

Displays first 16 inputs (See Table of Standard Inputs for Washer Extractors at the beginning of this section.)

(0) ABCDEFGHIJKLMNOP
+ - - + - + - + - - + - + + -

7
STEP + ABC

Displays second 16 inputs (See Table of Standard Inputs for Washer Extractors at the beginning of this section.)

(1) ABCDEFGHIJKLMNOP
- + + - + - - + - - + + - +

CANCEL
ESCAPE

Exits viewing inputs
"BARE MANUAL". Display returns to

RUN FORMULA
00 OR OK POWER OFF

MARK II ERROR MESSAGES

- Power-up messages
- Configuration/programming messages
- Run messages
- Miltdata messages

Power-up Messages

Initial Message CONFIG ERROR
TURN KEY TO PROG When key turned to PROGRAM ABCDEFGHIJKLMNQRST
00000000000000000000

Illegal data in CONFIGURE. Page AA of Program Menu, Mode 5=CONFIGURE is immediately displayed when key switch is turned to PROGRAM, or if key switch was already at PROGRAM at power up. Perform the following actions:

1. **Reconfigure**—Copy the codes on the machine's configuration tag (See Program Menu, Mode 5=CONFIGURE).
2. **Clear Memory**—See Program Menu, Mode 7=CLEAR ALL MEMORY (VOLUNTARILY).
3. **Rename** field-changed Step or Chem Names if desired (Program Menu, Modes 3 and 4).
4. **Reprogram** the Wash Formulas (See Program Menu Modes 1 and 6).



THREE WIRE DISABLED
any message

^EThe "three wire relay" became de-energized. Refer to RUN MESSAGES in this manual section for details.

FORM *xx* INCOMPLETE
TURN KEY TO PROG

^EControl detected incomplete or invalid formula that must be deleted from memory, usually caused by turning the keyswitch to RUN without ending the formula. Turning keyswitch back to PROGRAM will display and delete the invalid formula number, after which "OK TURN KEY TO RUN" will appear.

name BOARD FAILED
CHECK THIS BOARD

^EControl detects and displays a failed or missing control circuit board. A "missing" board can result from configuring for an option not provided for (example: too many chemical valves) or installing a new board or software that was configured for an option not on this machine. Board names include "16/8," "16 OUT #1," "16 OUT #2," "A/D," and "D/A."  resets control to permit access to the Program Menu.  will also permit running a formula in AUTOMATIC providing the problem is resolved, otherwise the fault must be cleared before the machine can run any formula in AUTOMATIC or MANUAL.

—KEYPAD ERROR—
key name

^EKeypad key shorted or stuck depressed; this message may appear on power-up or at formula end. Name of key appears on second line.

ACCUM. DATA ERROR

Applies to software 8900B and later. The control detected invalid accumulator data (usually because of a power surge at power ON). All totals must be cleared as explained in "Viewing, Printing and Clearing Accumulated Data," see table of contents.

^E = This message appears in English only.

Configuration/Programming Messages

FORM xx INCOMPLETE
TURN KEY TO PROG

^E Refer to POWER-UP MESSAGES in this manual section for details.

CLEAR MEMORY NOW
PRESS 4 + 5 + 6

Control detected an error in configuration or program memory, usually because power was lost (or Master Switch turned off) while keyswitch was at PROGRAM and, upon power up, the CPU could not be certain that the memory was not corrupted. When the CPU can be confident of uncorrupted memory, the control will power up in the Program Menu and display "OK TURN KEY TO RUN."

Fxx TMMQCCCHC LS
Sxx ILLEGAL INSERT !

User attempted to insert an illegal step in an existing formula. Examples include an attempted duplication of an END FORMULA or an EXTRACT.

Fxx TMMQCCCHC LS
Sxx ILLEGAL DELETE

An attempt was made to illegally delete a formula step. Examples include attempted deletion of an END FORMULA or a bath between two EXTRACTs.

Fxx COOLDOWN ILLEGAL
Sxx PRESS NEXT

Cooldown is allowed only if three conditions are met: 1) the machine is equipped with, and configured for Cooldown, 2) the cooldown is not the first step in a program, and 3) the preceding step is not an extract.

CCNN CHEM # AND NAME
0600 ILLEGAL CHEM

User attempted to program a chemical inject from a supply that was not configured. For example, a Chem 06 inject was attempted on a machine configured for only five injectors. See Program Menu, Mode 5=CONFIGURE.

—KEYPAD ERROR—
key name

^E Refer to POWER-UP MESSAGES in this manual section for details.

MEMORY IS FULL
PRESS NEXT

The program memory will be exceeded with the next step, so this formula must be deleted.

COPY SOURCE
xx DOES NOT EXIST

COPY OLD TO NEW (Program Menu, Mode 2) was attempted with a non-existent source formula. This message remains on the display, permitting entry of another formula number.

COPY DESTINATION
xx ALREADY EXISTS

COPY OLD TO NEW (Program Menu, Mode 2) was attempted to a destination containing a formula. Display remains on screen, permitting entry of another formula number.

ERROR IN CHECK SUM
NEXT TO PROCEED

On a machine receiving data during a down load operation, this machine indicates that downloading was unsuccessful. See Program Menu, Mode 6=DOWNLOAD.

^E = This message appears in English only.

Run Messages

| | |
|--|--|
| name BOARD FAILED CHECK THIS BOARD | ^E See explanation under POWER-UP MESSAGES in this section. |
| THREE WIRE DISABLED any message | ^E The “three wire relay” became de-energized. This relay provides control circuit power to the machine. Once energized by momentarily depressing START, it is held energized by its own normally open contact along with motor overloads, front and rear down switches, door interlock, etc. Should any of these contacts open, even momentarily, the machine stops and displays THREE WIRE DISABLED plus those specific reasons mentioned below. These messages will remain even if the contact only opened momentarily, and will reappear if the Master Switch is turned OFF and then ON again. These messages can only be cleared by pushing START, and then only if the fault has been cleared. |
| THREE WIRE DISABLED FAULT: DOOR | ^E Door interlock relay indicates door is or was open. |
| THREE WIRE DISABLED FAULT: WASH OVERLOAD | ^E Wash motor overload opened. |
| THREE WIRE DISABLED FAULT: VARIABLE SPEED | ^E Variable speed drive unit malfunctioned. Check the Variable Speed Drive Unit display for an error code. Refer to the manual for the specific combination of make, model, and size of Variable Speed Drive with consideration to the specific washer-extractor model, voltage, etc. for corrective actions. Then clear error and press START. |
| THREE WIRE DISABLED FAULT: DRAIN OVERLOAD | ^E Drain motor overload opened. |
| THREE WIRE DISABLED FAULT: E1 OVERLOAD | ^E E1 (low-speed extract) motor overload opened. |
| THREE WIRE DISABLED FAULT: E2 OVERLOAD | ^E E2 (high-speed extract) motor overload opened. |
| THREE WIRE DISABLED FAULT: FRONT UP | ^E Front of machine not full down, or Front Down switch, relay, or circuitry malfunctioned. |
| THREE WIRE DISABLED FAULT: REAR UP | ^E Rear of machine not full down, or Rear Down switch, relay, or circuitry malfunctioned. |
| THREE WIRE DISABLED SEE MANUAL | ^E An error condition occurred in the three wire circuitry which the control cannot specifically identify. |
| TOO LONG TO FILL | The time to fill to the commanded liquor level (Program Menu, Mode 5=CONFIGURE; decision I) has been exceeded. Check for low water pressure. |
| TOO LONG TO STEAM | The time to steam up to the commanded temperature (Program Menu, Mode 5=CONFIGURE; decision H) has been exceeded. Check steam pressure. |

^E = This message appears in English only.

| | |
|--------------------------------------|--|
| TOO LONG TO COOL | The time to cooldown to the commanded temperature was exceeded (Program Menu, Mode 5=CONFIGURE, decision J). See also "HOW TO COOLDOWN" in this manual. |
| SPEED SWITCH OPEN | Control sees speed switch open, indicating that the basket is rotating at speed which keeps speed switch open or a malfunction in the speed switch circuitry if the basket is stopped. |
| CHECK LEVEL SWITCH | Control detects an error in the level switch circuit. Example: High Level MADE and Low Level NOT MADE . |
| LEVELS STILL MADE | Level still made after a drain when the machine desires to enter extract, or desires to close the drain valve for the next bath. Check for drain obstructions, malfunctioning level switch, or inadequate drain time (Program Menu, Mode 5=CONFIGURE, decision G). |
| CHECK PROBE | Control determined that a temperature probe malfunctioned. Check probe position and termination connections at resistor board. If these check OK, disconnect probe from processor board and check resistance between leads and between each lead and ground. Lead-lead resistance should be from 2K to 35K ohms. Infinite resistance should exist between either lead and ground. |
| RECYCLE FAILURE | Machine recycled more than five times in a single extract step. Check load balance and excursion switch adjustment. |
| BRAKE FAULT | Brake pressure switch saw insufficient air pressure in the brake release air cylinder to guarantee that the brake has released. Possible causes include low air pressure (frequently caused by too small an air supply pipe to the machine, especially on HYDRO-CUSHION machines, as the pushdown and the brake operate simultaneously, thus requiring maximum air flow to the machine.) Other causes include leaking piston cup in an air cylinder, pinched or leaking brake or push down air lines, leaking quick release air valve, or faulty pressure switch or pilot air valve. |
| CHECK DRAIN CLUTCH | (FxP and certain other models) Indicates speed switch not open immediately before extraction begins; possible causes include electric drain clutch not engaged, drain motor did not accelerate basket, or speed relay failure. |
| *—KEYPAD ERROR—* <i>key name</i> | ^E Refer to POWER UP MESSAGES in this manual section for details. |
| INVALID PASSWORD | Password protection for manual intervention was configured (Program Menu, Mode 5=CONFIGURE; decision X) and a manual formula modification was attempted without entering the proper password within 10 seconds of initiating MODIFY FORMULA mode. The proper password must be re-entered if 10 seconds elapse between keystrokes in MANUAL MODE A. |
| MANUAL EXTRACT: MUST HAVE LEVEL 2 | The controller requires not less than Level 2 before <u>any</u> extract. |

^E = This message appears in English only.

Mildata Messages

| | |
|--------------------|---|
| INVALID WORK ORDER | User entered a work order number at the machine which could not be matched in the MILDATA computer. |
| INVALID GOODS CODE | User entered a goods code at the machine which could not be matched in the MILDATA computer. |
| INVALID CUST CODE | User entered a customer code at the machine which could not be matched in the MILDATA computer. |
| INVALID EMPLOYEE # | User entered an employee number at the machine which could not be matched in the MILDATA computer. |
| INVALID FORM DATA | The machine requested a formula from the MILDATA computer which did not exist or was not a valid formula. |
| DATA UNLOCATABLE | This message indicates a nested error (invalid data in an area not directly accessed by the machine). For example, this message will appear if a valid goods code is entered at the machine, but the formula associated with that goods code is invalid or inaccessible. |

Section

6

Supplemental Information

THE HARDWARE IN SERIAL-TYPE MICROPROCESSORS

General

Milnor[®] serial microprocessor controls are designed specifically for Milnor[®] machines and systems. Along with certain external electromechanical relay logic and sensing devices, they control all machine and system functions. Not every microprocessor includes all the components described in this section.

The Microprocessor Components

This is a list of all components for Milnor[®] microprocessor controllers. Not every Milnor[®] microprocessor controller includes all the following components.

1. Keypad or Keyboard—Depending upon the model/type, the keypad may have 12, 30, or 58 buttons. The different keypads are not interchangeable.

2. Keyswitch—Selects run/program modes. The key may be removed only in *run*. Never leave the key accessible to unauthorized personnel.

3. Display—Depending upon the model/type, the display may be either liquid crystal, fluorescent, or CRT. The different displays are not interchangeable.

4a. Power Supply (NOT for CBW[®] System)—Converts control circuit AC voltage to +12VDC, -12VDC, and +5VDC for the CPU board. On dryers and some other machines, a second, identical power supply performs the same function for all the peripheral boards, which are mounted in an enclosure separate from the CPU.

A minimum 14AWG ground wire must be connected between the grounds on the CPU and the peripheral board(s). This ground is installed at the factory when both enclosures are mounted on the same machine, as in washer-extractors. The ground wire must be provided during installation when the CPU enclosure and its associated peripheral board enclosures are remote from one another as in dryers.

Although the +12VDC and -12VDC are not adjustable, the +5VDC for the CPU is very sensitive. The power supply must be adjusted most accurately, so the actual voltage at the CPU board is between 4.95VDC and 5.1VDC as measured by an accurate digital voltmeter.

4b. Power Supply (CBW[®] System Only)—The Milnor[®] CBW[®] System utilizes two discrete power supplies to convert control circuit AC voltage to +12 VDC, -12 VDC, and +5VDC for the CPU board and peripheral boards.

One power supply (ESPS) is a 40-watt power supply located in the Miltron cabinet. It powers the peripheral boards in the Miltron cabinet, including the optional load cell interface board and A/D board for a weighing conveyor, the CPU board and the memory expansion board, and the monitor interface board.

Although the +12VDC and -12VDC are not adjustable, the +5VDC for the CPU is very sensitive. The power supply must be adjusted accurately, so the actual voltage at the CPU board is between 4.95VDC and 5.1VDC as measured by an accurate digital voltmeter.

The second power supply (PSO) is a 120-watt power supply which provides +12VDC, -12VDC, and +5VDC to the peripheral boards located on the tunnel. This power supply provides for the adjustment of the +12VDC voltage, the -12VDC voltage, and the +5VDC voltage. If these voltages require adjustment, set the +5VDC to provide no less than +4.8VDC at the module electric box farthest from the power supply, as measured by an accurate digital voltmeter. If necessary, adjust the +12VDC to 12.00VDC and the -12VDC to -12.00VDC as measured by an accurate digital voltmeter.

If the +5VDC at the peripheral board nearest PSO is at least +5.25VDC when the voltage at the peripheral board farthest from PSO is +4.8VDC or less, suspect loose MTA connections or inadequate wiring somewhere between the nearest and farthest peripheral boards.

5. CPU (Processor) Board—The Central Processing Unit (CPU) processes data received from the various inputs, stores information, and responds to each keypad entry with the appropriate action. It may be mounted in an enclosure separate from its peripheral boards. The CPU contains E-PROMs programmed by the Milnor[®] factory with fixed instructions (software) that determine how the machine functions. Depending upon machine model/type, the CPU chip can be either an Intel 8085 or an Intel 8088.

Although the E-PROMs do not require battery backup, the CPU board utilizes a battery which normally assures that the user-programmable memory will be retained for two to three months without external power. See below and "IMPORTANT OWNER/USER INFORMATION . . ." (see Table of Contents).

6. Memory Expansion Board—Increases memory space available to the processor. This board is used with 8088 CPU board in some applications.

7. Battery—Provides memory retention backup when power is *off*. The battery is mounted directly on 8085 CPU boards, and mounted separately for 8088 CPU boards. A capacitor on the 8088 CPU board provides enough power to retain memory for several hours after the battery has been disconnected. Once fully charged (see "IMPORTANT OWNER/USER INFORMATION . . ."), the battery backup is reliable for 90 days with no power applied.

8. Opto-Isolator Board—Optically isolates inputs to the CPU for electronic noise immunity. Opto-Isolators are incorporated into the 8088 CPU board; thus this separate board is only required for 8085 CPUs.

9. I/O Board—16/8 input-output contains 16 solid-state signal input devices and eight output relays. The input devices are capable of faithfully conducting a low VA 12VDC ground signal to the CPU. The output relays are socket-mounted SPDT, 12VDC electromechanical relays with contacts capable of faithfully conducting a *maximum* of 25VA at 110/120VAC (0.2 ampere or 200 milliamperes at 110/120VAC) or 12.5 VA at 24VAC (0.5 ampere or 500 milliamperes at 24VAC). The output will be either 24VAC or 110/120VAC depending on the machine model/type.

These outputs and their power source are intended only to drive another relay with higher contact ratings, that in turn may drive a pump, valve, solenoid, etc., from a separate power source. **Never use these outputs to directly drive a pump, valve, or solenoid unless the maximum current required never exceeds the above values. Higher ampere or VA loads will burn out traces on the printed circuit board or possibly overload and damage the control circuit transformer.**

Standard I/O board—Used in all devices requiring I/O boards except those listed below.

High-speed I/O board—Used only in the following devices and configurations: E6N, J6N, and T6N washer-extractors equipped and configured for *both variable basket speed and electronic balancing*; Milrail configured for high-speed boards; and all configurations of the M7E centrifugal extractor.

10. Output Board—A 16-output board contains 16 output relays, the same type as those described above.

11. A/D Board (Analog to Digital Converter)—Converts analog voltage signals, such as temperature, to a digital signal that can be utilized by the CPU. Up to a maximum of eight A/D channels may be provided on a single board. Although seemingly identical, the A/D boards used to sense air temperature in the dryer, water temperature in washer-extractors and dye machines, water temperature in the tunnel, and weight for a weighing conveyor are all different. **The different types are clearly marked with different part numbers, which are mentioned in the wiring diagram set and are not interchangeable.**

12. D/A Board (Digital to Analog Converter)—Converts digital signals from the processor to an analog voltage between 0 and 5VDC (e.g., provides the analog signal to the dryer gas valve position actuator and dye machine steam position actuator).

13. CRT Board—Receives display instructions from the processor and generates the signals to the CRT to create the desired displays; used in controllers such as the Miltron and Miltrac controllers and Device Master systems.

▲ CAUTION ▲

The CRT board can be plugged in backwards, even though the cabinet/bracketry makes this difficult to do and labeling on the parent board states the proper orientation. Use care to orient the board properly, otherwise microprocessor components may burn out.

14. Resistor Boards—Although seemingly identical, resistor boards are quite different. The different types are clearly marked with different part numbers, which are mentioned in the wiring diagram set and *are not interchangeable*.

- a. **For Temperature-Sensing System**—Used with A/D board in washer-extractors and Dye-Extractors[®] as part of temperature-sensing system; not required on continuous batch washers because necessary circuitry is included on other (standard) CBW[®] printed circuit boards.
- b. **For Gas Valve**—Used with D/A board in temperature control circuit of gas dryers; converts 0-5VDC to 4-20 milliamperes for modulating gas valve.
- c. **For Steam Valve**—Used with D/A board in temperature control circuit of older steam dryer models; converts 0-5VDC to 4-20 milliamperes for modulating steam valve. See “4-20MA Output Board” in this section.

15. Signal Conditioner for Thermocouple—Amplifies the output from a thermocouple so an A/D board can use the signal.

16. Rotation Safety Board—Used in dryers. Reads rotational safety proximity switch to confirm that the basket is turning.

17. Temperature Probes—Two types of temperature probes are used, depending on equipment type:

Thermistor temperature probes—A temperature-sensitive resistor whose resistance changes with respect to temperature; uses include washer-extractors, textile machines, and continuous batch washers.

Thermocouple temperature probes—A connection of dissimilar metals which produces a voltage with respect to its temperature; uses include dryers.

18. Weigh Scale Interface Board—Regarding machine logic, this is located between the load cell of the weighing conveyor (CONWA) and the weighing conveyor A/D board. It interprets data from the conveyor load cell to the A/D board.

19. 4-20MA Output Board—Used on newer dye machines and steam dryers with temperature control. See “Resistor Boards/c. For Steam Valve” in this section.

The Serial Communications Port

All Milnor[®] serial microprocessors have a serial port with a nine-pin receptacle and plug to pass data to other devices via one of several special serial cables to *Download* or to *Print data* when their software supports these functions (e.g., see programming information). For more information on the various separate serial cables required for these functions, see external serial link cable information in this manual (see Table of Contents), if applicable.

Which Boards Are Used in Various Devices

| Board Device | 8088 CPU | I/O | OUTPUT | A/D | D/A | CRT | Opto- Isolator | Temp Sensing Resistor | Gas Valve Resistor | Steam Valve 4-20MA | Signal Condi- tioner | Rotation Safety | Weigh Scale Interface |
|----------------------------|-------------|---------------------------|----------------|---|----------------|-----|-------------------|-----------------------------|--------------------------|--------------------------|----------------------------|--------------------|-----------------------------|
| COSHA | 1 | 2 ¹ | — | — | — | — | — | — | — | — | — | — | — |
| COBUC | 1 | 2 ¹ | — ¹ | — | — | — | — | — | — | — | — | — | — |
| DEVICE MASTER | 1 | 2 ¹ | — ¹ | — | — | 1 | — | — | — | — | — | — | — |
| DRYER | 1 | 1 ¹ | 1 | 1 ⁴ | 1 ² | — | — | — | 1 ² | — ² | 1 | 1 | — |
| DYE | 1 | 2 | 2 | 1 ⁴ | 1 | — | — | 1 | — | 1 | — | — | — |
| LINEAR COSTA | 1 | 1 ¹ | — | — | — | — | — | — | — | — | — | — | — |
| LINK MASTER | 1 | — | — | — | — | — | — | — | — | — | — | — | — |
| MILTRAC | 1 | — | — | — | — | 1 | — | — | — | — | — | — | — |
| PRESS | 1 | 2 ¹ | 1 ¹ | 1 | — | — | — | — | — | — | — | — | — |
| EXTRAC- TOR | 1 | 1 ¹ | 1 ¹ | — | — | — | — | — | — | — | — | — | — |
| VERTSTO | 1 | 2 | — | — | — | 1 | — | — | — | — | — | — | — |
| W/E (MARK I) | NOTE 7 | 1 ¹ | 1 ¹ | 1 ^{3,4} | — ¹ | — | 1 | 1 | — | — | — | — | — |
| W/E (MARK II) | 1 | 1 ¹ | 1 ¹ | 1 ^{3,4} | — ¹ | — | — | 1 | — | — | — | — | — |
| CBW [®] System | 1 | 2+1 per mod- ule | — ¹ | 1 per 8 ⁴ mod- ules 1,5,6 | — | 1 | — | — | — | — | — | — | 1 ⁵ |

- Boards can be added for options
- For gas dryers and steam dryers with temperature control
- For washer-extractors with temperature option
- Although seemingly identical, the A/D boards for sensing air temperature in dryers, water temperature in washer-extractors and dye machines, water temperature in tunnels and weight for weighing conveyors are all different. **The different types have different part numbers, are clearly marked, and are not interchangeable.**
- Required for CBW[®] system with weighing conveyor
- Required for Reuse/Cooldown and/or Overhead Fill tanks
- The Mark I washer-extractor control used an 8085 CPU

NOTE: Additional boards may be required for certain other options.

DIP Switches and How To Set Them

Every peripheral board has eight DIP switches which establish the address of each board so it may communicate serially with its own CPU, as though on a "party line," while sending and receiving only its own messages. In a battery of machines, the DIP switch settings are identical for each identical peripheral board in each identical machine (e.g., each first I/O board (I/O-1) in each washer-extractor has the identical DIP switch setting). When a CPU must communicate with a higher level control (e.g., when all dryers communicate with the Milnet[®] system), the higher level control must know the address of each CPU. For 8085 CPUs, a board-mounted DIP switch performs this function; however, for the 8088 CPU, the higher level control knows the address of each CPU because that information was established during configuration (e.g., see *Miltrac Address* configure decision in the programming manual for any device that communicates with Miltrac).

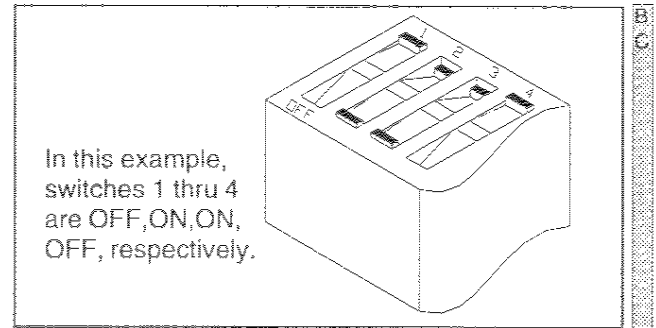

FIGURE 1 (MSFDA401DE)
DIP Switch ON/OFF Positions

DIP Switch Settings

| Board Device | A/D | D/A | I/O-1 | I/O-2 | I/O-3 | I/O-4 | Output-1 | Output-2 | Output-3 |
|-------------------------------------|--|-------------------------|-----------------|--------------------|-------------------|---------------------|------------------------|--------------------------|--------------------------|
| COSHA | — | — | 2-8 ON 1 OFF | 1, 3-8 ON 2 OFF | 3-8 ON 1,2 OFF | 1,2,4-8 ON 3 OFF | — | — | — |
| COBUC | — | — | 2-8 ON 1 OFF | 1, 3-8 ON 2 OFF | 3-8 ON 1,2 OFF | 1,2,4-8 ON 3 OFF | 2-4, 6-8 ON 1,5 OFF | 1,3,4,6-8 ON 2,5 OFF | 3,4,6-8 ON 1,2,5 OFF |
| DEVICE MASTER | — | — | 2-8 ON 1 OFF | 1, 3-8 ON 2 OFF | 3-8 ON 1,2 OFF | — | 2-4, 6-8 ON 1,5 OFF | 1,3,4, 6-8 ON 2,5 OFF | 3,4, 6-8 ON 1,2,5 OFF |
| DRYER | 2-5, 7, 8, ON 1,6, OFF | 2-4,7,8 ON 1,5,6 OFF | 2-8 ON 1 OFF | 1, 3-8 ON 2 OFF | — | — | 2-4, 6-8 ON 1,5 OFF | — | — |
| DYE- EXTRAC- TOR [®] | 2-5,7,8 ON 1,6 OFF | 2-4,7,8 ON 1,5,6 OFF | 2-8 ON 1 OFF | 1, 3-8 ON 2 OFF | — | — | 2-4,6-8 ON 1,5 OFF | 1,3,4,6-8 ON 2,5 OFF | 3,4,6-8 ON 1,2,5 OFF |
| LINEAR COSTA | — | — | 2-8 ON 1 OFF | 1,3-8 ON 2 OFF | — | — | — | — | — |
| PRESS | 2-5,7,8 ON 1,6 OFF | — | 2-8 1 OFF | 1,3-8 ON 2 OFF | 3-8 ON 1,2 OFF | 1,2,4-8 ON 3 OFF | 2-4,6-8 ON 1,5 OFF | 1,3,4,6-8 ON 2,5 OFF | — |
| CENTRI- FUGAL EXTRAC- TOR | — | — | 2-8 ON 1 OFF | 1, 3-8 ON 2 OFF | 3-8 ON 1,2 OFF | — | 2-4,6-8 ON 1,5 OFF | 1,3,4, 6-8 ON 2,5 OFF | — |
| VERTSTO | — | — | 2-8 ON 1 OFF | 1,3-8 ON 2 OFF | — | — | — | — | — |
| WASHER- EXTRAC- TOR | 2-5,7,8 ON 1,6 OFF | 2-4,7-8 ON 1,5,6 OFF | 2-8 ON 1 OFF | 1,3-8 ON 2 OFF | — | — | 2-4,6-8 ON 1,5 OFF | 1,3,4,6-8 ON 2,5 OFF | — |
| CBW [®] System | See schematics for DIP switch positions on Continuous Batch Washer and the MILTRON controller. | | | | | | | | |
| | Shaded cells denote options. | | | | | | | | |

HOW TO CHANGE EPROMS IN MICROPROCESSORS AND WHERE TO CHECK THE DC VOLTAGES

Occasionally, software enhancements become available. Depending upon the software change, the new software EPROMs (Erasable, Programmable, Read-Only Memory) may be offered for sale or for no charge to the customer. When a set of EPROMs is changed in the field, ensure that the software version being installed matches the machine hardware and that EPROMs are installed in the proper socket positions and orientation.

How To Change EPROMs

▲ WARNING ▲



SHOCK HAZARD—Electrical components on the machine conduct high voltage that will kill or seriously injure you on contact.

☞ **Lock OFF** and tag out electrical power at the main (wall) disconnect before beginning this procedure.

1. Make sure all power to the machine is *off*.
2. Locate the EPROMs as described in “Location of EPROMs on Processor Board” in this section. Note the orientation of the EPROMs as shown in FIGURES 3, 5, 7, and 9.
3. Slip a small flat tool underneath the EPROM, and carefully remove each old EPROM from its base, taking note of their numerical order (see FIGURES 3 and 7) and orientation to the key notch on the socket.
4. Install new EPROMs, making sure the key notch on the EPROM is properly oriented and that all pins enter the proper holes in the socket (FIGURE 1). If necessary, slightly bend the pins on the EPROMs to align them in the socket. After inserting each EPROM, verify that all pins are seated in the socket.

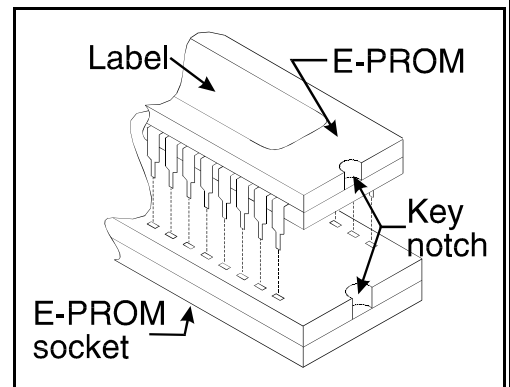

FIGURE 1 (MSSM0217AE)
Properly Seating the EPROM

▲ CAUTION ▲



COMPONENT DAMAGE HAZARD—Incorrectly installing any EPROM may cause EPROM burn out, machine failure, or display error.

☞ **Match each EPROM** with its corresponding socket. Each EPROM will *work* in only one socket, although it may physically *fit* in others.

☞ **Align EPROM** so every pin mates with the correct hole in the socket.

Verifying Proper EPROM Installation—After installing new EPROMs, apply power to the machine and turn the machine *on*. If the EPROMs are properly installed, the display will continue with the normal display sequence when powering up. If the display is blank or appears unusual, turn the machine *off* at once and check the orientation of the EPROMs.

B
C

Location of EPROMs on Processor Board

Depending on machine model and type, the CPU chip can be an Intel 8085 or an Intel 8088. Each microprocessor board requires at least one EPROM for proper operation, but the EPROMs are located differently, depending upon the type of board. This information describes the location and arrangement of the EPROM chips on each type of board. It also describes where to check the voltages required by the processor board.

8085 Processor Boards, *NOT Coin Machine*—See FIGURE 3. Install EPROM #1 at the end of the row, then #2, #3, and #4. Chip #4 goes next to the two soldered chips on the board. See FIGURE 2 for where to check voltages.

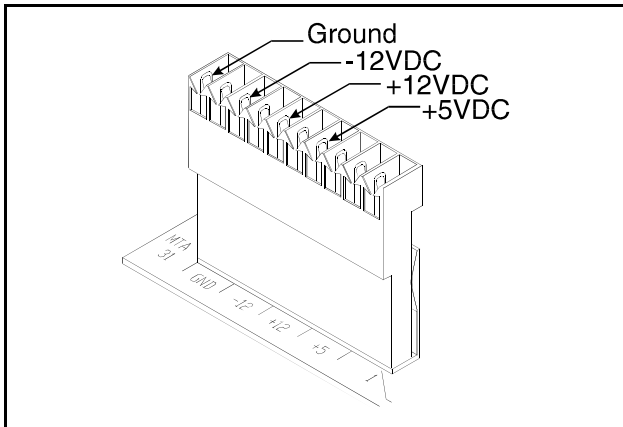

FIGURE 2 (MSSM0217AE)
MTA-31 on 8085 Processor Board
(wires not shown for clarity)

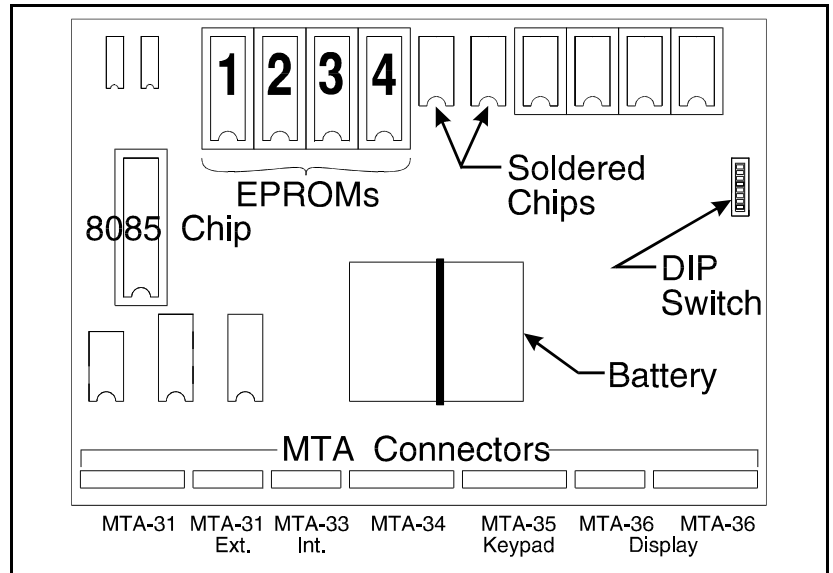

FIGURE 3 (MSSM0217AE)
8085 Processor Board (NOT Coin Machine)

8085 Coin Machine Processor Boards—See FIGURE 5. Install the single EPROM in socket IC7 below connector W34. These boards have no battery.

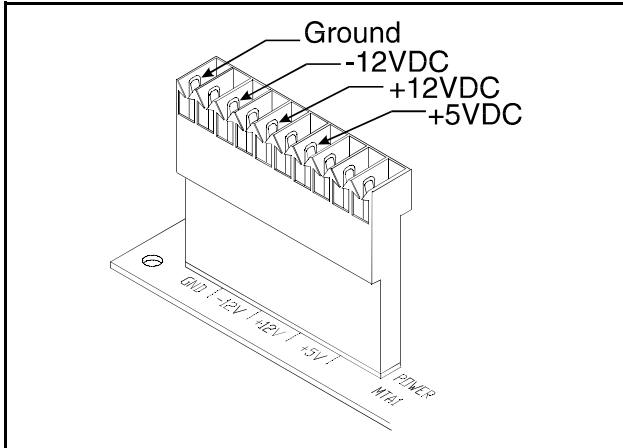

FIGURE 4 (MSSM0217AE)
MTA-1 in 8085 Coin Machine
(wires not shown for clarity)

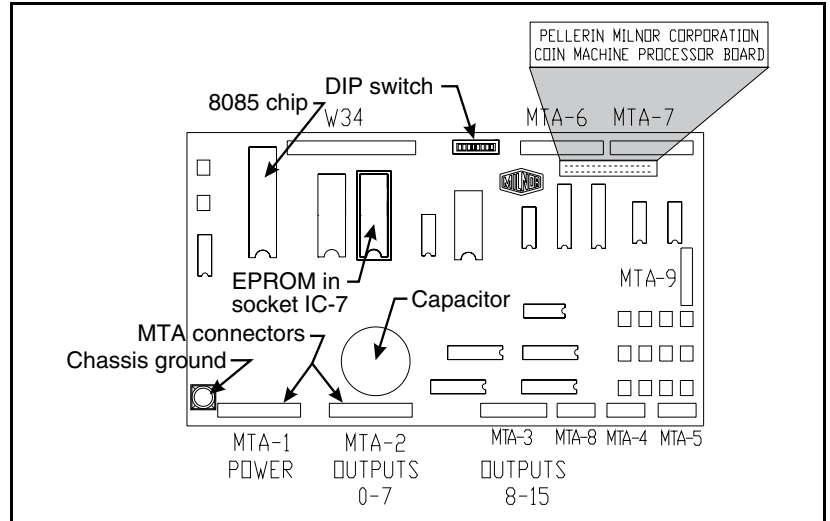

FIGURE 5 (MSSM0217AE)
8085 Coin Machine Processor Board

H

B
C

8088 Processor Boards Without Memory Expansion Board—See the table of EPROM locations (below) and FIGURE 7. If the set consists of only one EPROM, install it in socket A of FIGURE 7. If two EPROMs comprise the set, install EPROM #2 in socket A and EPROM #1 in socket B. **Always install highest numbered EPROM in socket A.** If the set consists of more than two EPROMs, a Memory Expansion Board must be present in the machine along with the processor board.

8088 Processor Boards With Memory Expansion Board—See the table of EPROM locations below and FIGURE 7. If the EPROM set consists of three or more EPROMs, install the two highest numbered EPROMs (e.g., EPROMs #3 and #4 of a four-chip set) *on the processor board*, with the highest numbered E-PROM (EPROM #4 of a four-chip set) in socket A, and the EPROM with the second highest number (EPROM #3 of a four-chip set) in socket B. *Install the remaining EPROM(s) on the Memory Expansion Board* with the highest numbered of the remaining EPROMs (e.g., EPROM #2 of a four-chip set) in socket IC-1 on the Memory Expansion Board and EPROM #1 in socket IC-2.

| EPROM Locations on 8088 Processor Board and Memory Expansion Board | | | | |
|--|---|---|------|------|
| EPROMS in Set | E-PROM Location by Socket (see FIGURE 4) | | | |
| | A | B | IC-1 | IC-2 |
| 4-chip set | 4 | 3 | 2 | 1 |
| 3-chip set | 3 | 2 | 1 | — |
| 2-chip set | 2 | 1 | — | — |
| 1-chip set | 1 | — | — | — |

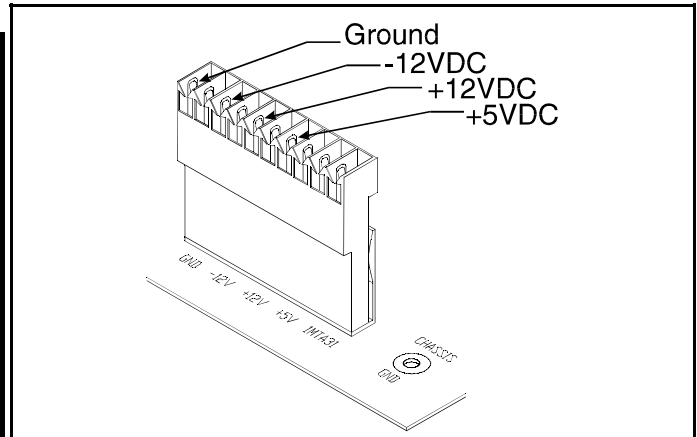

FIGURE 6 (MSSM0217AE)
1MTA-31 on 8088 Board (wires not shown for clarity)

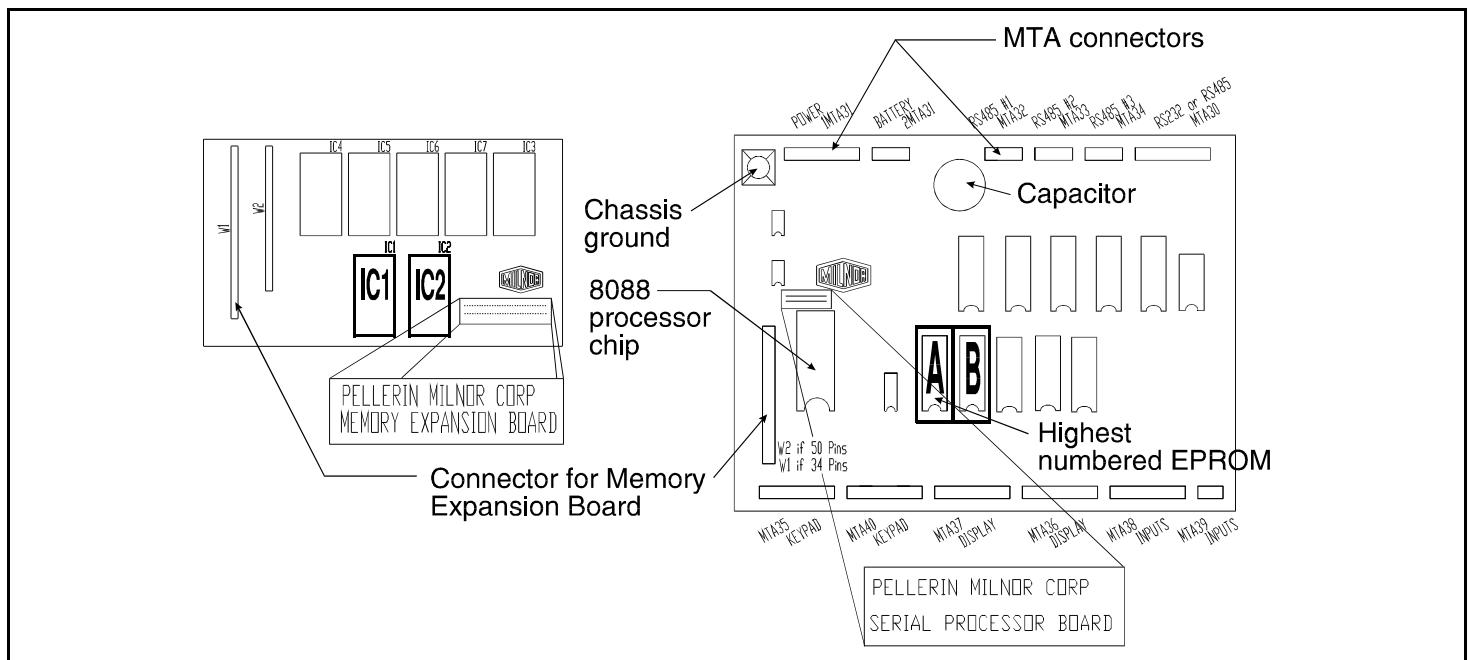

FIGURE 7 (MSSM0217AE)
8088 Processor Board and Optional Memory Expansion Board

80186 Processor Boards—This processor board is used on all Milnor system controllers (Miltron, Mildata, etc.) equipped with a color monitor, and on textile processing machines with software versions 95000 and later. The single EPROM on this board is located in socket IC-2.

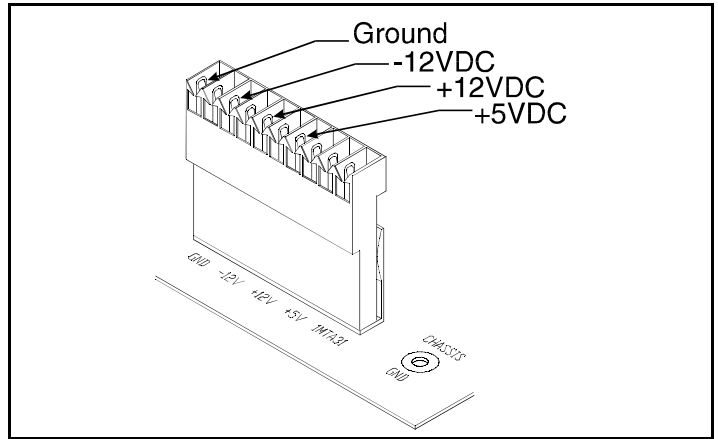

FIGURE 8 (MSSM0217AE)
1MTA-31 on 80186 Board (wires not shown for clarity)

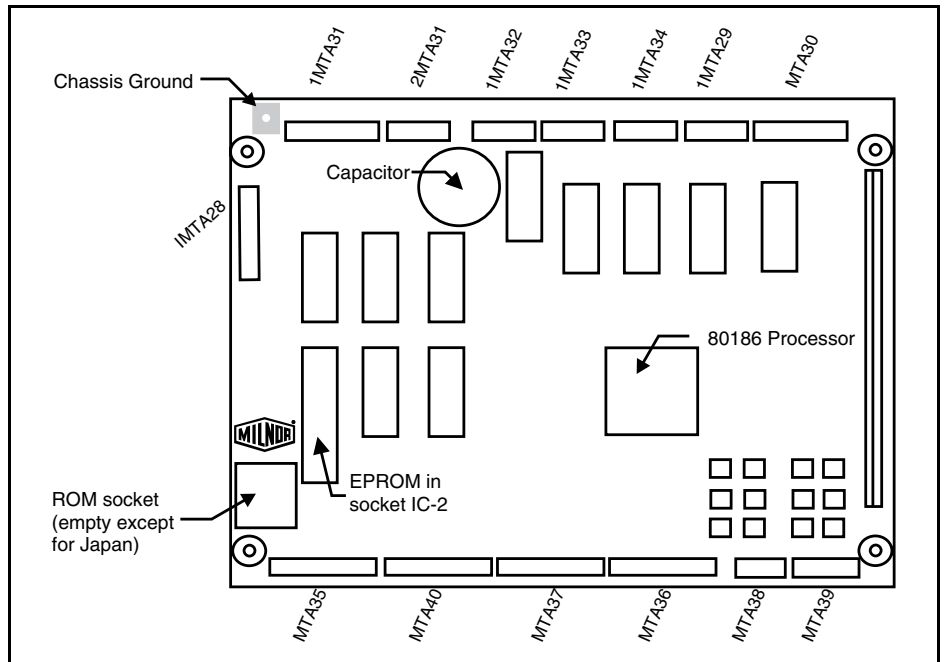

FIGURE 9 (MSSM0217AE)
80186 Processor Board

THE EXTERNAL SERIAL LINK CABLES AND HOW TO CONSTRUCT THEM

General

Only three wires (two signal wires plus a ground, referred to in this section as a *serial link*) are required to transfer data from one Milnor[®] device to another. However, because the two optional serial communicating functions (*Download* and *Print Data*, but not interconnected networks such as Milnet[®]/Miltrac or Mildata[®] systems) are conducted through a single external DIN-type, 9-pin connector, different *serial links* will be required for the two functions; it may be necessary to temporarily disconnect one plug from the connector and insert another to access the other optional function. *Non-optional* serial communications (as between Mildata[®] networks and a bank of washer-extractors, or as between Milnet[®]/Miltrac systems and the press, shuttle, and dryers in a CBW[®] system) are hard-wired internally either at the factory or during system installation. Thus, except for some field retrofit situations, these network systems generally do not use the external connector mentioned above.

In Mildata[®] systems, the functions of *Download* and *Print Data* are usually performed at the Mildata[®] PC itself, but each washer-extractor (and certain other machines if their software supports it) can also *Download* or *Print Data* via its external connector.

| |
|--------------------|
| ▲ CAUTION ▲ |
|--------------------|

If *Download* or *Print Data* is performed from serial downloader-to-machine or machine-to-machine with machines in a Milnet[®]/Miltrac or Mildata[®] network system, **ALL** energized machines on the network will receive the downloaded data. Turn *off* power to any machines to which you do not wish to *Download*.

Pin Identification

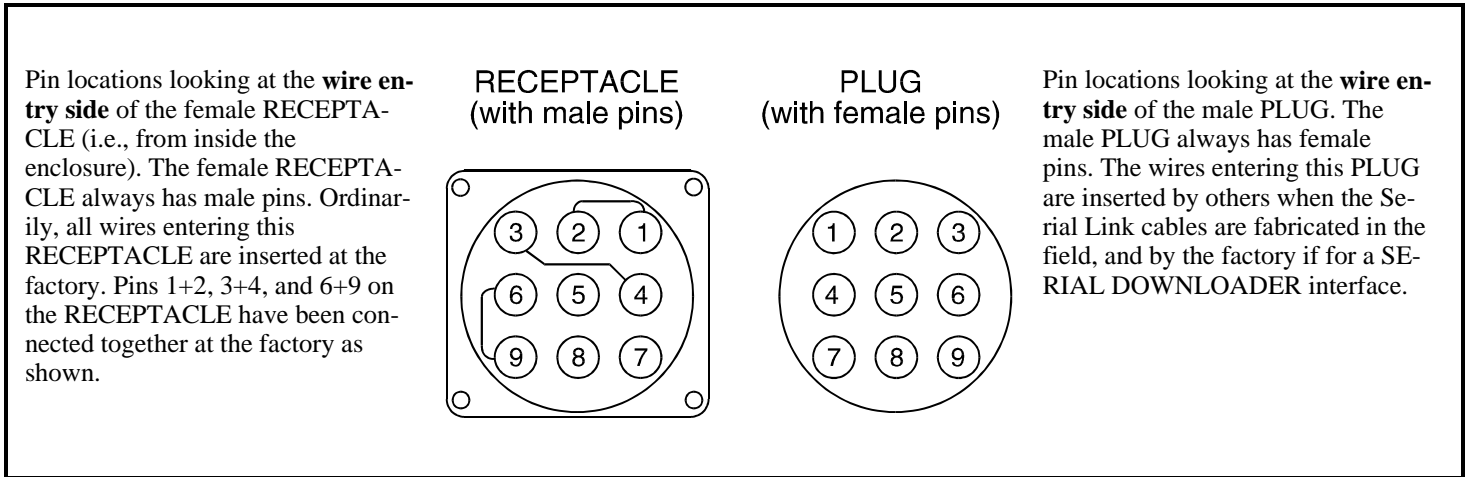

FIGURE 1 (MSSM0227AE)
Pin Locations in the External Serial Link Connector

Pin Assignments in the External Connector

| PIN NUMBER | FUNCTION | WIRES ON RECEPTACLE INSIDE ELECTRICAL ENCLOSURE | |
|------------|-------------------|---|-----------------|
| | | Number | Color |
| 1+2 | SERIAL LOW | DLL | BLUE and BLACK |
| 3+4 | SERIAL HIGH | DLH | BLUE and RED |
| 5 | CLEAR TO SEND | CTS | BLUE and ORANGE |
| 6+9 | ELECTRONIC GROUND | 2G | BLUE and WHITE |
| 7 | TRANSMIT DATA | TXD | BLUE and ORANGE |
| 8 | +5DC | V1 | BLUE |

⚠ CAUTION ⚠

AVOID EQUIPMENT DAMAGE—Never connect pin 8 between any machines or to the printer. This pin conducts +5VDC from the machine's power supply. Pin 8 is used only to power the SERIAL DOWNLOADER INTERFACE. If pin 8 is connected to any pin in the connector or the printer or any other machine, the two volt sources will clash and burn up expensive electronic components in both machines.

How To Construct (Wire) the Serial Link Cables

The Type of Cable Wire To Use—Use 18AWG four-conductor shielded cable. Connect the shield to the ground at one end only. See the various drawings below.

▲ CAUTION ▲

AVOID EQUIPMENT DAMAGE—Never connect pin 8 between any machines or to the printer. This pin conducts +5VDC from the machine's power supply. Pin 8 is used only to power the SERIAL DOWNLOADER INTERFACE. If pin 8 is connected to any pin in the connector or the printer or any other machine, the two volt sources will clash and burn up expensive electronic components in both machines.

To Download From Machine-to (from)-Serial Downloader

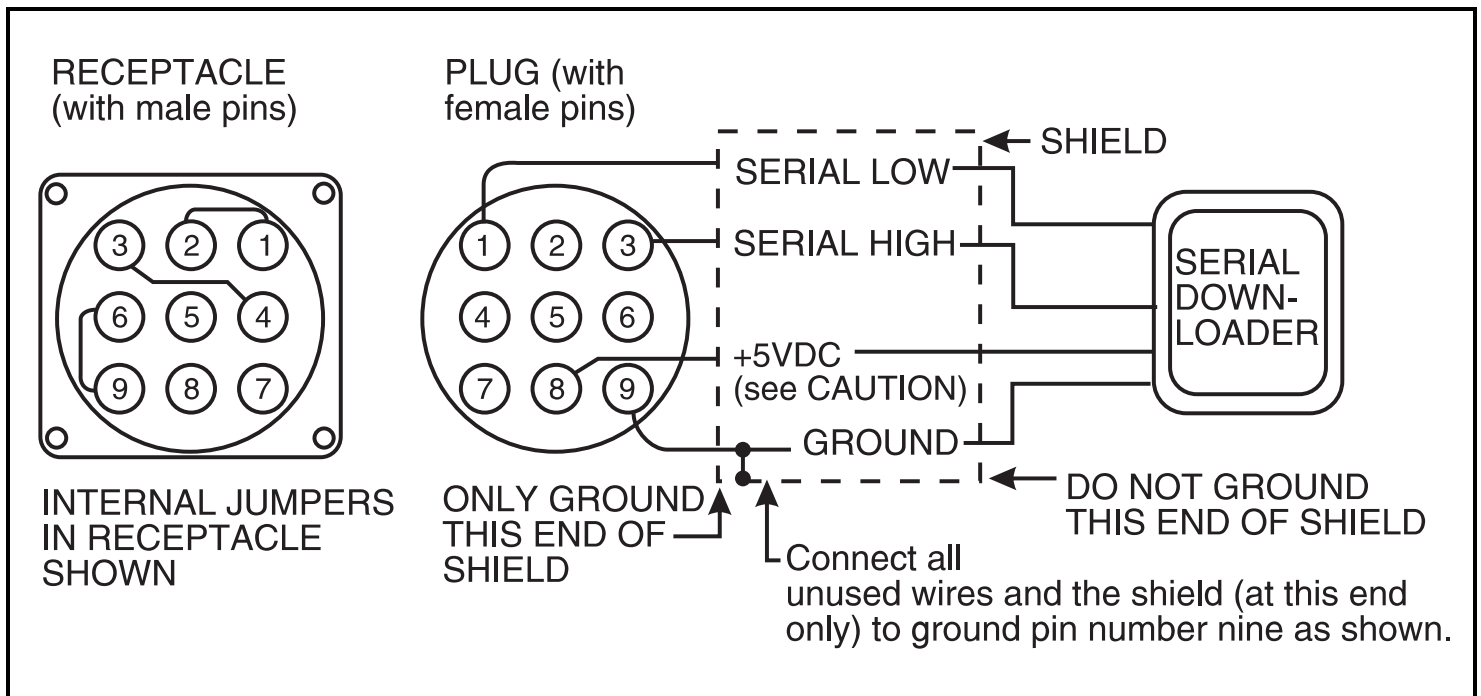

FIGURE 2 (MSSM0227AE)
Connections for Downloading Machine-to (from)-Serial Downloader

To Download From Machine-to-Machine(s)—FIGURE 3 illustrates how to construct a daisy chain serial link cable to download data from one machine to several others simultaneously. It is best to program one (MASTER) machine (or to DOWNLOAD using SERIAL DOWNLOADER-TO-MACHINE if the data is already stored in the downloader) and then to use a serial link to program the remainder from that MASTER. Any machine on the serial link can be the MASTER.

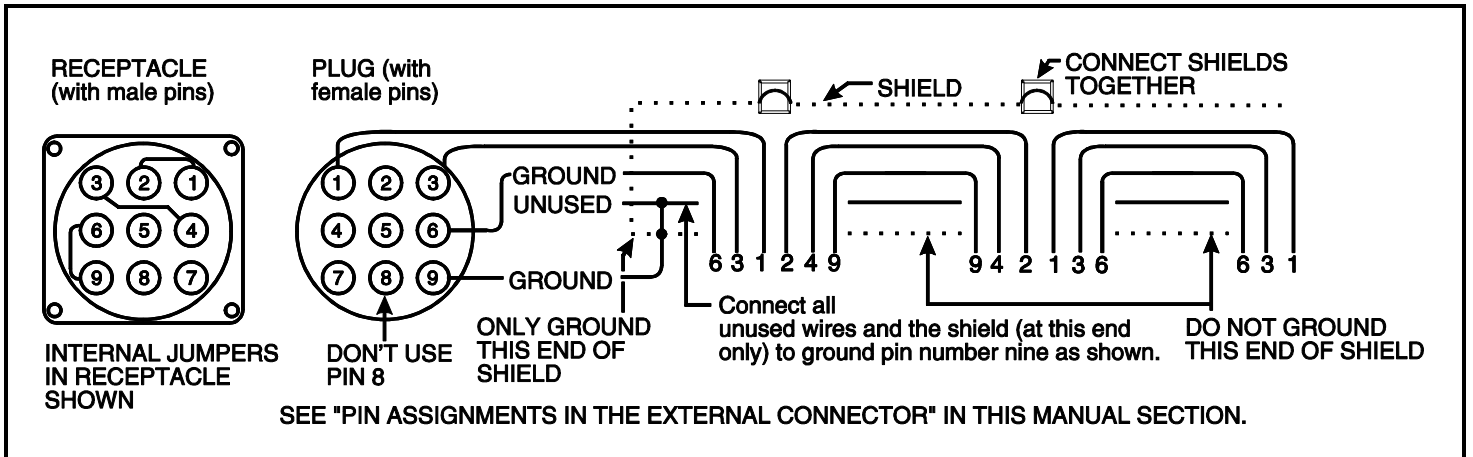

FIGURE 3 (MSSM0227AE)
Connections for Downloading From Machine-to-Machine(s)

For Print Data—The connections shown in FIGURE 4 are made at the factory if the factory furnishes the printer, or by whomever provides the printer. Where applicable, see the appropriate programming section in this manual for an explanation of the Print Data feature (see Table of Contents).

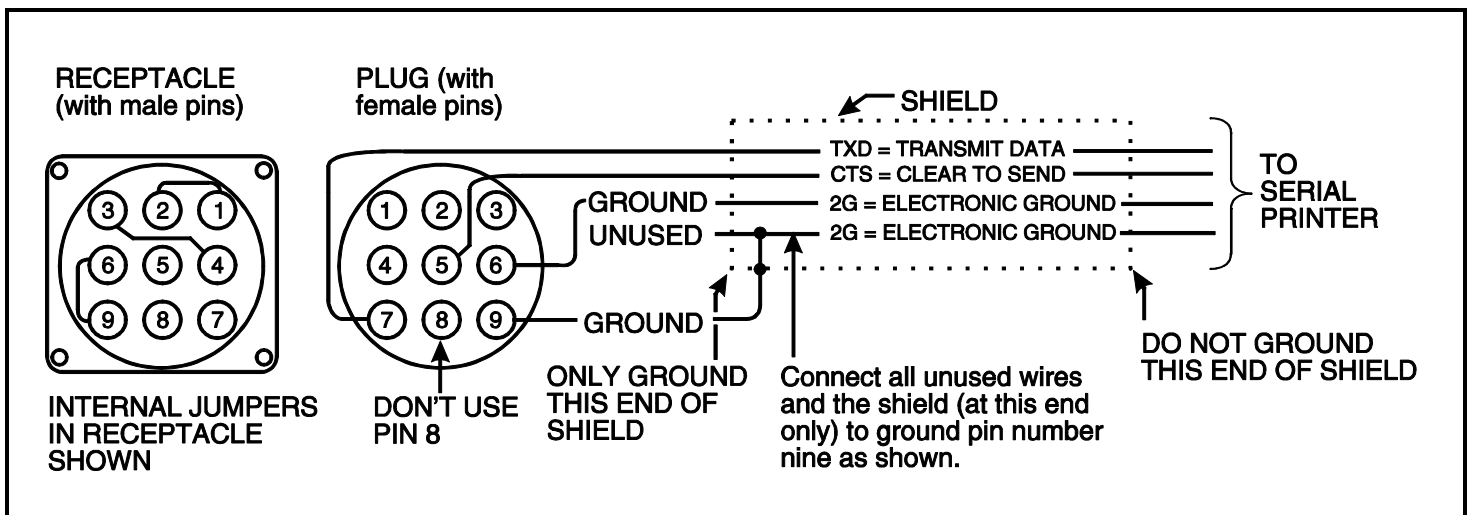

FIGURE 4 (MSSM0227AE)
Machine-to-Printer Connections

C SERIAL PRINTER SPECIFICATIONS FOR EPSON LX810 PRINTER

Printers used with Milnor[®] machines must adhere to the specifications shown in **Table 2, Part A**. As of this writing, the Epson LX810 (replaces LX800) is the only printer supplied or supported by Milnor[®]. This printer must be used with the Epson 8143 Serial Interface board (which is mounted inside the printer housing) and one of the following Milnor[®] interface cables, available as of November 4, 1992 (Mildate 92761):

| Part Number | Description |
|-------------|---|
| 10YMK2PNTR | Printer Cable for Mark II Washer-extractor, Dryer, and Mark VIII Miltron controller |
| 10YCBWPNTR | Printer cable for non-serial Miltron controller |

We cannot guarantee that any other printer/interface board/cable combination will work correctly.

There are 11 jumpers and a DIP switch set on the Epson 8143 Serial Interface board. When the printer is furnished by Milnor[®], these jumpers and DIP switches are pre-set at the Milnor[®] factory and must remain at their factory settings. The jumper settings are shown in **Table 1** and the DIP switch settings are shown in **Table 2, Part B**.

There are also two DIP switch sets on the printer which determine character spacing and other characteristics. These DIP switches are accessible in a window on the right side of the LX810 and the rear of the LX800. The characteristics controlled by these switches vary somewhat between the LX800 and the LX810 and even between older and newer versions of the LX810. Thus, **Table 2, Part C** lists the settings required for Milnor[®] applications by function, not by switch number. See your Epson User's Manual.

Table 1: Epson 8143 Jumper Settings (Applies to All MILNOR[®] Machines)

| JUMPER NAME | SETTING |
|-------------|---------|
| J1 | OFF |
| J2 | OFF |
| J3 | OFF |
| J4 | OFF |
| J5 | ON |
| JRS | ON |
| JC | OFF |
| JNOR | ON |
| JREV | OFF |
| JF | ON |
| JX | OFF |

⚠ CAUTION ⚠

Because all printers are not equal, Milnor[®] cannot know how to specify switch and jumper settings for each available printer. We regret that we are unable to guarantee or troubleshoot any printer other than the Epson LX810 (or LX800)/Epson 8143 Serial Interface/Milnor[®]-specified cable combination, with the specifications, jumper settings, and DIP switch settings shown below, and we cannot guarantee that any printer will work correctly unless we furnish and test it.

**Table 2: Epson LX800 and LX810
Serial Printer Specifications and DIP Switch Settings**

| | Non-Serial Miltron (Mark VII-A and earlier) | Mark II Dryer, Miltrac, Coste (Vertsto), Serial Miltron (Mark VIII and later) | Mark II Washer- extractor before software version 89014 | Mark II Washer- extractor Software with software version 89014 and later | | |
|--|---|---|--|--|---------------|-----|
| PART A—PRINTER SPECIFICATIONS | | | | | | |
| These specifications are always required. | Serial Port | RS232 | RS232 | RS232 | RS232 | |
| | Baud Rate | 9600 | 9600 | 2400 | 9600 | |
| | Word Length | 8 Bit | 8 Bit | 8 Bit | 8 Bit | |
| | Stop Bit | 1 Stop Bit | 1 Stop Bit | 1 Stop Bit | 1 Stop Bit | |
| | Parity | Does not matter | Even | Even | Even | |
| | Parity Check Enabled | No | Yes | Yes | Yes | |
| PART B—DIP SWITCH SETTINGS ON EPSON 8143 SERIAL INTERFACE BOARD | | | | | | |
| These DIP switch settings are only for EPSON 8143 Serial Interface board with LX800/LX810 printer. We cannot guarantee that any other printer will work correctly. | These settings are made at the MIL-NOR [®] factory and must remain as shown. | 1 | ON | ON | ON | ON |
| | | 2 | OFF | OFF | OFF | OFF |
| | | 3 | OFF | OFF | OFF | OFF |
| | | 4 | OFF | OFF | ON | OFF |
| | | 5 | ON | ON | ON | ON |
| | | 6 | OFF | ON | ON | ON |
| | | 7 | OFF | OFF | OFF | OFF |
| | | 8 | ON | ON | ON | ON |
| PART C—REQUIRED FUNCTION SELECTIONS VIA DIP SWITCHES ON PRINTER | | | | | | |
| The required function selections are only for the LX800/LX810 with EPSON 8143 Serial Interface board. We cannot guarantee that any other printer will work correctly. DIP switch numbers and functions vary with the printer model. See your Epson User's Manual. | Character spacing | 10 cpi/Normal | 10 cpi/Normal | 10 cpi/Normal | 10 cpi/Normal | |
| | Shape of zero | Slashed | Slashed | Slashed | Slashed | |
| | Character table | Graphics | Graphics | Graphics | Graphics | |
| | Short tear-off | Invalid | Invalid | Invalid | Invalid | |
| | Draft printing speed | High | High | High | High | |
| | Page length | 11 inches | 11 inches | 11 inches | 11 inches | |
| | Cut sheet feeder mode | OFF | OFF | OFF | OFF | |
| | Skip over perforation | OFF | OFF | OFF | OFF | |
| | Auto line feed | OFF | OFF | OFF | OFF | |
| | International character | Must select United States, regardless of Milnor [®] software language version. | | | | |
| | Paper-out detection | Active | Active | Active | Active | |
| | Print quality | Draft | Draft | Draft | Draft | |

HOW “CHEMWAIT” WORKS IN MILNOR MARK I, II, III, IV, AND V MICROPROCESSOR WASHER-EXTRACTOR CONTROLLERS

“CHEMWAIT” is a feature in the Milnor washer-extractor controller whereby a central chemical injection system can service several washer-extractors. When the chemical injection system is serving another machine, each washer-extractor controller can accept a command from the injection system to “stop the timer and do not start the injection signal.”

An independent output from Milnor to the chemical system declares: **“THIS MACHINE DESIRES TO INJECT ONE OR MORE UNNAMED CHEMICAL(S).”** (The same independent output is used regardless of the chemical(s) that will be subsequently requested.) To cause the Milnor timer to stop and delay the **“COMMENCE CHEMICAL INJECTION”** signals, an independent input from the chemical system to Milnor must respond, **“WAIT”** (within two seconds).

In the *absence* of a **“WAIT”** response, the Milnor signal(s) start two seconds after the inject request, or two seconds after the **“WAIT”** response is extinguished. The duration of the inject signals will be whatever is commanded in the washing program.

“WAIT” commands will be ignored unless the machine has desired to inject less than two seconds before.

When several washer-extractors desire chemicals simultaneously, it is the central chemical injection systems’ responsibility to decide which machine will receive chemicals first. It is also the central chemical injection systems’ responsibility to cope with the situation when one or more washer-extractors simultaneously desire more than one chemical, although the latter case may be avoided by only commanding one chemical injection at a time—using Milnor’s exclusive “do not drain” feature to subsequently inject more than one chemical in the same bath.

The **“DESIRES TO INJECT”** and **“WAIT”** signals must be via potential-free contacts capable of faithfully handling 10 MA (.01 amperes) at 5 VDC. The specific **“COMMENCE CHEMICAL INJECTION”** signals will be either 120 VAC or 240 VAC, depending on the specific MILNOR model, and via relay contacts capable of conducting a maximum of 9 VA (i.e., a maximum of either 80 MA (.08 amperes) at 120 VAC or 40 MA (.04 amperes) at 240 VAC).

“CHEMWAIT” is presently available in all Mark I, II, III, IV, and V controllers, but does require the optional #2 output board. Ask factory for more information.

